



MM

Plug Sliding Door System 2

Maintenance Manual

Version	1.1
Release date	2020-05-20
Document ID	PS2200001
Project name	Plug Sliding Door System 2
Project ID	PS2

We welcome millions
of people every day

Revision history

Revision	Date	By	Description
1.1	2020-05-20	Prepared: <i>M.Stoelinga</i>	Replaced Manual with Document. Adjusted references. Added repair option to sensitive edge chapter. Added Torque settings chapter
1.0	2019-07-19	Prepared: <i>M.Stoelinga</i>	Chapter microswitches updated. Added reference. Update Acronyms and Abbreviations. Minor textual and lay-out changes.
0.6	2018-12-20	Prepared: <i>M.Stoelinga</i>	Minor lay-out changes. Removed 10.000 cycle reference.
0.5	2018-12-04	Prepared: <i>M.Stoelinga</i>	Frequency changed. Moved "Clamping force test" from "Safety parts" to "Part inspections". Added the sentence: "Contact your local Agent for parts." Adjusted filter regulator check for electric systems with non-Ventura DCU.
0.4	2018-11-15	Prepared: <i>M.Stoelinga</i>	Rephrased safety checks. Added "Only applicable for electric systems" to spindle nut. Changed reference from appendix to installation manual. Adjusted contact information.
0.3	2018-11-13	Prepared: <i>M.Stoelinga</i>	Adjusted emergency release. Removed step 3. Added contact page. Added simple check, sensitive edge procedure. Small changes to introduction for safety parts and wear parts.
0.2	2018-11-02	Prepared: <i>M.Stoelinga</i>	Maintenance frequencies changed.
0.1	2018-10-10	Prepared: <i>M.Stoelinga</i> <i>M.Delorme</i>	Initial version.



Preface

The Quality System of Ventura Systems is accredited to EN ISO 9001:2015.

All rights reserved. Disclosure to third parties of this document or any part thereof, or the use of any information contained therein for purposes other than provided for by this document, is not permitted, except with prior and express written permission from Ventura Systems.

Table of Contents

1 Introduction.....	6
1.1 Purpose.....	6
1.2 Scope	6
1.3 Definitions	6
1.4 Acronyms and Abbreviations	6
1.5 References.....	6
1.5.1 External documents	6
1.5.2 Ventura Systems documents	6
1.6 Overview.....	7
2 Door installation safety	8
2.1 General	8
2.2 Disclaimer	8
2.3 Safety alert symbols	9
2.4 Safety instructions.....	10
3 Maintenance.....	11
3.1 Safety parts.....	11
3.1.1 Lever block	11
3.1.2 Emergency release	12
3.1.3 Sensitive edge.....	13
3.1.4 Obstruction detection unit.....	14
3.1.5 Micro switches (Switch & Cams).....	15
3.2 Wear parts.....	18
3.2.1 Spindle Nut.....	18
3.2.2 Over center soft stopper.....	19
3.2.3 Cushioning rubber bearing house.....	20
3.2.4 Guide rollers	20
3.2.5 Catch block.....	21
3.2.6 Bottom stopper	21
3.3 Parts inspections	22
3.3.1 Door shafts	22
3.3.2 Filter regulator	23
3.3.3 Tension steel cables	24
3.3.4 Clamping force test	24
3.3.5 Grease bearing house	25
3.3.6 Grease spiral cable guiding shaft	25
4 Torque Settings.....	26
5 Operational checks	28
5.1 Operation and controls	28
5.2 Safety checks	28
6 Contact	29

List of Figures

Figure 1: Lever block	11
Figure 2: Dismount the door leaf	13
Figure 3: Disconnect the sensitive edge connectors	13
Figure 4: connect multimeter to the obstruction detection unit	14
Figure 5: Adjustment tool VB8538	15
Figure 6: over center position	15
Figure 7: Micro switch open position.....	16
Figure 8: Micro switch closed position.....	16
Figure 9: Position 6mm adjustment tool	16
Figure 10: Adjusting micro switch closed position.....	17
Figure 11: Position 8mm adjustment tool	17
Figure 12: Spindle nut	18
Figure 13: Overcenter electric with unlock cylinder.....	19
Figure 14: Overcenter pneumatic with unlock cylinder	19

Figure 15: Pneumatic without overcenter function	19
Figure 16: Rubber cushioning ring	20
Figure 17: Bottom guide roller	20
Figure 18: Distance between bottom lever and guiding rail	20
Figure 19: Catch wedge and catch block locations	21
Figure 20: Check catch wedge	21
Figure 21: Bottom stopper	21
Figure 22: Top bearing door shaft	22
Figure 23: Bottom bearing door shaft	22
Figure 24: Camozzi filter regulator	23
Figure 25: Camozzi regulator	23
Figure 26: Tension meter	24
Figure 27: Obstruction test setup	24
Figure 28: Spiral cable guiding shaft	25
Figure 29: mark the fasteners with a torque marker	26
Figure 30: torque setting overview	26
Figure 31: World map Ventura locations	29

List of Tables

Table 1: Definitions	6
Table 2: Acronyms and abbreviations	6
Table 3: External documents	6
Table 4: Ventura Systems documents	6
Table 5: Maintenance frequencies	11
Table 6: General contact information	29
Table 7: Parts contact information	29

1 Introduction

1.1 Purpose

This maintenance manual describes maintenance and small adjustment procedures for the Ventura plug slide door system. Together with the Installation manuals and system drawings makes a complete set of maintenance documentation. It is important to follow all instructions. All instructions must be conducted without air/electric power unless mentioned otherwise. The instructions should be executed for the left and right door leaf when the system contains two door leaves. A well-adjusted door system is less vulnerable to failure. The right maintenance is crucial for the durability of the door system.

1.2 Scope

The purpose of this document is to guide trained service mechanics through the maintenance steps of the plug slide door system. When repairs have to be made, the mechanic needs to use the repair manual, or the proper service instruction.

1.3 Definitions

Definition	Description
Wear part	Wear is progressive damage to a part caused by relative motion with respect to another substance or part.
Safety part	A safety part is a part, which is important to the overall safety of a system.

Table 1: Definitions

1.4 Acronyms and Abbreviations

Abbreviation	Description
DCU	Door Control Unit
HQ	Headquarters
IATF	International Automotive Task Force
IM	Installation Manual
ISO	International Standardization Organization
PS	Plug Slide
PSI	Pound-force per Square Inch
REG	Regulation
QM	Quality Manual

Table 2: Acronyms and abbreviations

1.5 References

1.5.1 External documents

Reference	Description	Date
APTA:2013	Standard bus procurement guidelines : A standardized request for proposal contract form for the transit industry	2013-05-01
IATF 16949:2016	Automotive quality management system standard	2016-10-01
ISO 9001:2015	ISO Standard for Quality Management Systems – Requirements.	2015-10-01
REG 107 Rev 08	Uniform provisions concerning the approval of category M2 or M3 vehicles with regard to their general construction (Incorporating all valid text up to: Supplement 1 to 08 series of amendments)	2019-10-15
TS 155 Rev 2	Bus door safety systems	2017-11-23

Table 3: External documents

1.5.2 Ventura Systems documents

Reference	Type	Description	Revision	Date
PS2200002	IM	Plug Sliding Door System 2 : Installation Manual	1.2	2019-10-24
QM000001	DG	Documentation Guideline	3.1	2020-01-14

Table 4: Ventura Systems documents



1.6 Overview

Section 1 gives an introduction, definitions and overview of this document.

Section 2 contains the general door system safety instructions, safety symbols and disclaimer.

Section 3 contains the maintenance instructions.

2 Door installation safety

2.1 General

Safety of the operator and bystanders is one of the main concerns in designing and developing a new piece of equipment. Ventura's door systems have the proper safety features for common use of the system. An accident can often be avoided by recognizing potentially hazardous situations before an accident occurs. As you install, operate, or maintain the door system, you must be alert to potential hazards. Make sure you have the necessary training, skills and tools to perform any assembly, or maintenance procedures. Improper operation and maintenance of this door system may result in a dangerous situation that may cause injury or death.

Ventura Systems cannot anticipate every possible circumstance that may involve a potential hazard. The warnings in this document and on the product are not all-inclusive. If a method of installation or operation is used, which is not specifically recommended by Ventura Systems, you must satisfy yourself that it is safe for you and for others. You should also ensure that the door system will not be damaged or be made unsafe by the installation and/or operational methods you choose. The information, specifications and illustrations in this document are based on the information that was available at the time this document was written and can change at any time without notice.

2.2 Disclaimer

The information contained in this maintenance document is based upon reliable technical data at the time the document was published. These instructions are intended for use by persons having the technical knowledge to maintain this door system. The instructions are to be used at the maintenance mechanic's own discretion and risk. Ventura Systems assumes no responsibility for results obtained or damage incurred from the use of this material either in whole or in part by the installer. This document provides basic instructions for the maintenance of the door system in a step-by-step sequence that will work in most types of maintenances. While effort has been made to ensure the information in this document is correct and complete, we would appreciate it if you would contact us in case of errors.

2.3 Safety alert symbols

This document contains safety messages which alert you to potential personal injury hazards. Obey all safety messages in this document to avoid possible injury or death. The following key words and layouts calls for your attention: DANGER, WARNING, CAUTION and NOTICE. Below are examples of these safety messages. The NOTE message is used for additional information but these are not threatening for the mechanic, bystanders, nor the door system.



DANGER!

Indicates an imminently hazardous situation which, if not avoided, will result in death or serious injury. This signal word is limited to the most extreme situations.



WARNING!

Indicates a potentially hazardous situation which, if not avoided, could result in death or serious injury.



CAUTION!

Indicates a potentially hazardous situation which if not avoided, may result in minor or moderate injury.

NOTICE

Indicates that equipment or property damage can result if instructions are not followed.

NOTE

Additional information important but not threatening for people or to the system.

2.4 Safety instructions



WARNING!

This door system is designed for a specific application;

DO NOT modify or use this unit for any application other than for which it was designed.

Door systems operated improperly or by untrained personnel is dangerous. Lack of operation knowledge may cause high risk.

Do not install this door system if it is damaged. If you are in doubt if the door system has a defect, immediately stop the installation and contact Ventura Systems.

Do not connect the door system to air or electric supply during the maintenance process. If the manual states otherwise, follow the manual.

Do not attempt to install the door system under influence of drugs or alcohol.

NOTICE

Do not modify the door system or safety devices. Unauthorized modifications may impair its function and safety.

If equipment has been altered in any way from the original design, Ventura Systems does not accept any liability for injury or warranty.

If replacement of parts is necessary, genuine factory replacement parts must be used to restore the door system to its original specifications.

*always disconnect the air and/or electric power while replacing parts. Safety features may not be active while replacing parts.

Ventura Systems will not accept responsibility for damages as a result of the use of unapproved parts.

While working on the Ventura door systems wear appropriate personal protective equipment.

This list may include but is not limited to:

- Protective shoes with slip resistant soles
- Protective goggles, glasses or face shield
- A hard hat

Follow the regional and country laws and safety precautions.

3 Maintenance

Maintenance of a door system should only be performed when the bus is positioned on a flat surface to prevent distortion/twisting of the bus body, which can lead to inaccurate measurements of the portal.

Whenever the amount of cycles is past, we advise to execute the applicable maintenance. At the table below, we address the chapter names.

Cycles assumption	Minimal maintenance	Applicable for
75.000	Every 3 months	Safety parts Operational checks
150.000	Every 6 months	Wear parts
300.000	Every 12 months	Parts inspections

Table 5: Maintenance frequencies

Execute at least the minimal maintenance intervals.

3.1 Safety parts

The checks in this chapter are very important. If these parts are not installed correctly, it can have great consequences for the safety of the system. When the system has two door leaves, the checks must be executed for both sides.

Ventura Systems recommend to execute all safety checks regularly and at least according to the maintenance intervals mentioned in the table "Maintenance frequencies".

3.1.1 Lever block

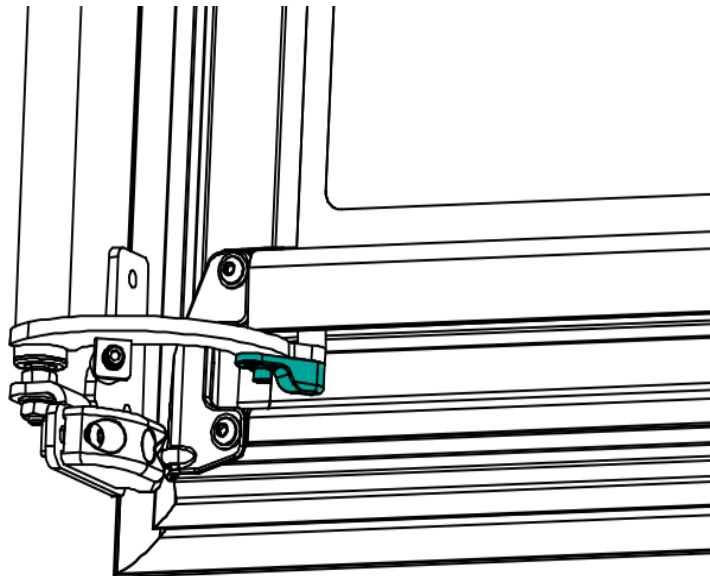

Figure 1: Lever block



WARNING!

When the lever block is not in place, the door leaf could get off the guiding roller when twisted, leading to situations with a high risk of injury to persons. It is very important the lever block is in place.

1. Check if the lever block is present at the bottom of the lever.
2. Check if the lever block is in the right position. It has to be inside the rail of the door leaf.
3. Check if the bolt is on torque following the installation manual.

3.1.2 Emergency release

Apply power and/or pressure to the system and put the door(s) in closed position.



CAUTION!

Be aware the system could move when applying power and/or pressure to the system.

1. When the system is active, activate the emergency release.
The following events should occur.
2. The power/pressure is released from the system.
3. The door(s) can be opened manually.
 - Reset the emergency release.
 - Open and close the door(s) using the power source.



WARNING!

Remove the power and/or pressure from the system after executing this step and before you continue.

3.1.3 Sensitive edge

- Press against the right mid seal at a height of 1 meter or less. The doors go to open position.
- Press against the left mid seal at a height of 1 meter or less. The doors go to open position.

When the door leaves do not open when pressing the mid seals as described, perform the following checks or execute the repair instruction.

Disconnect the sensitive edge.

- Remove the bolts which connect the door leaf to the door arm.
- Disconnect the connector from the spiral cable **The full door leaf could be removed to continue or a second engineer needs to hold the door, while executing the checks.**
- Connect a multimeter to the connector of the sensitive edge.

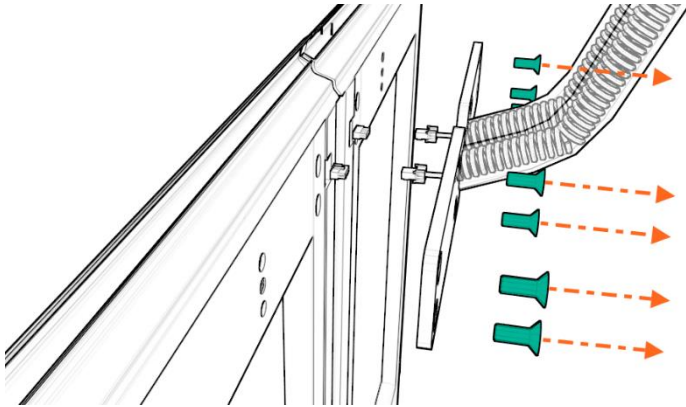

Figure 2: Dismount the door leaf

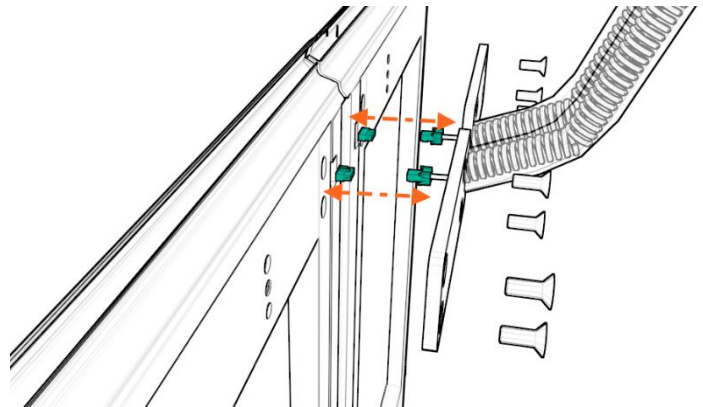

Figure 3: Disconnect the sensitive edge connectors

1. Be sure there is no force pressing the mid seal which can activate the sensitive edge. Resistance is 1200 or 8200 Ω depending on the resistor of the sensitive edge.
2. Apply force onto the mid seal of the door leaf. Resistance is approximately 0. $\sim 0 \Omega$

In case all checks are approved, reinstall the door leaf.

Follow the adjustment steps in the installation manual. Redo the teach-in procedure described in the installation manual.

NOTE

The sensitive edge is malfunctioning when the resistance is infinite. $\infty \Omega$.

3.1.4 Obstruction detection unit

Apply power and/or pressure to the system and put the door(s) in closed position.



CAUTION!

Be aware the system could move when applying power and/or pressure to the system.

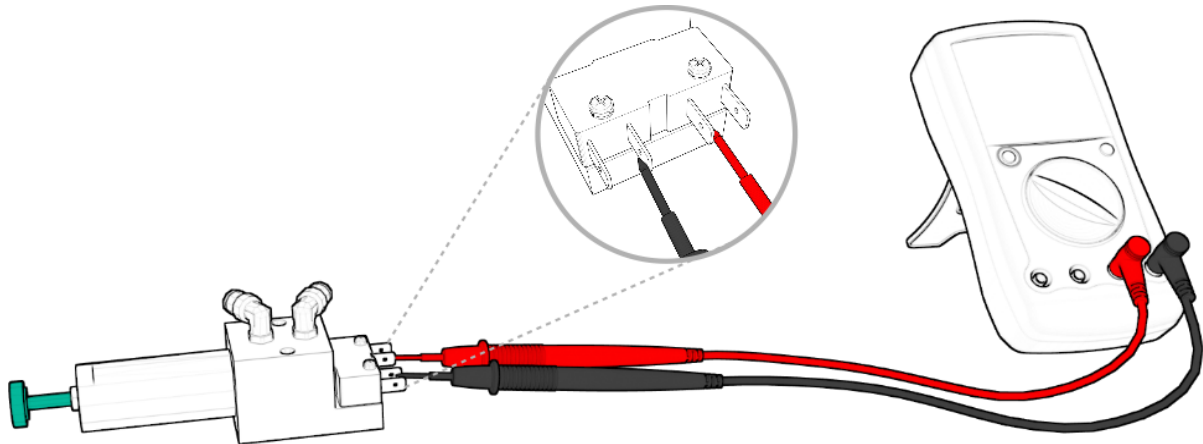

Figure 4: connect multimeter to the obstruction detection unit

1. If a signal is measured, the obstruction detection unit works properly.



WARNING!

Remove the power and/or pressure from the system after executing this step and before you continue.

3.1.5 Micro switches (Switch & Cams)

The micro switches are optional. When the door system has one or more micro switches do the following checks. When the door system has no micro switches, skip this step.

Door mechanism that go over center need to be adjusted using the adjustment tool 6 mm – 8 mm P/N VB8538.

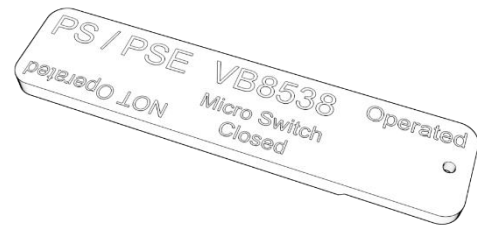

Figure 5: Adjustment tool VB8538

Door systems that go over center either have a type 1 or a type 2 soft stopper (1) (see image).

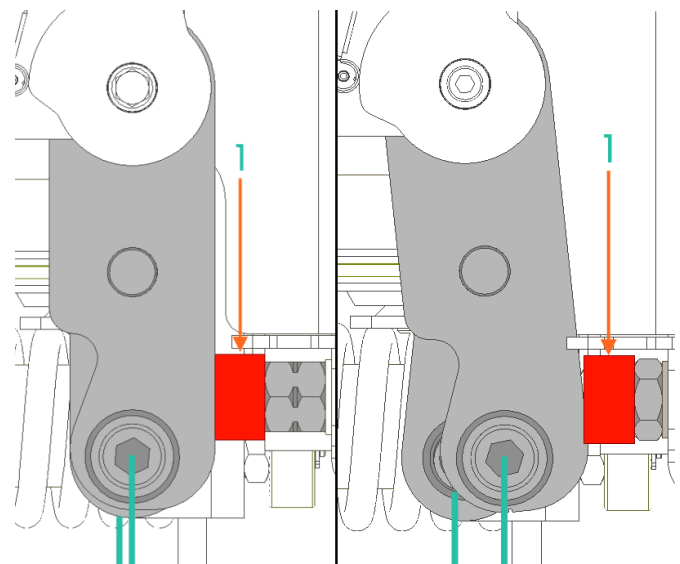

Figure 6: over center position



WARNING!

Pinch-point hazard!

The following steps have to be performed when parts of the door system are moving.

When the doors are in open position, the micro switch open (1) has to be activated. This micro switch is not adjustable.

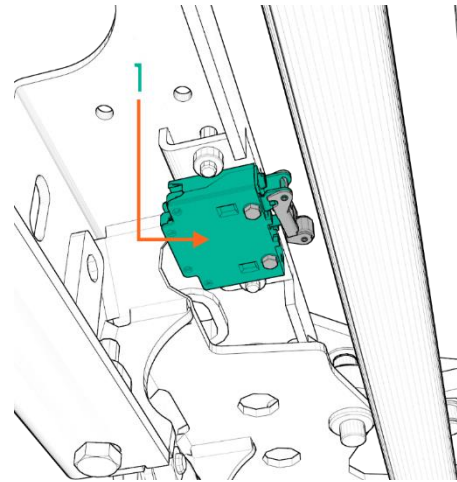

Figure 7: Micro switch open position

When the doors are in closed position, the micro switch closed (2) has to be activated. If the micro switch closed is not activated follow the next steps to adjust the micro switch closed position (2).

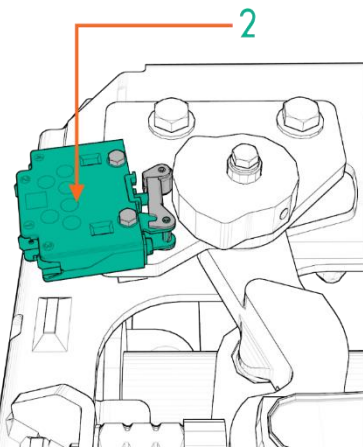

Figure 8: Micro switch closed position

- Place the door in an open position
- Place the 6mm side of the adjustment tool between the door mechanism and the end stopper (See image)
- Close the door and move on to the next steps.
Be aware of pinch point hazard.

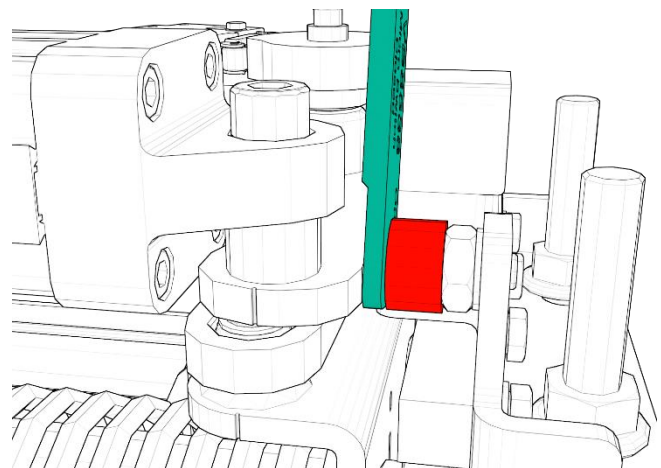

Figure 9: Position 6mm adjustment tool



- Unscrew the cam with an Allen key
- Turn the cam to a position where the micro switch activates (See image)
- Fasten the cam with an Allen key
- Place the door in an open position and move on to the next steps

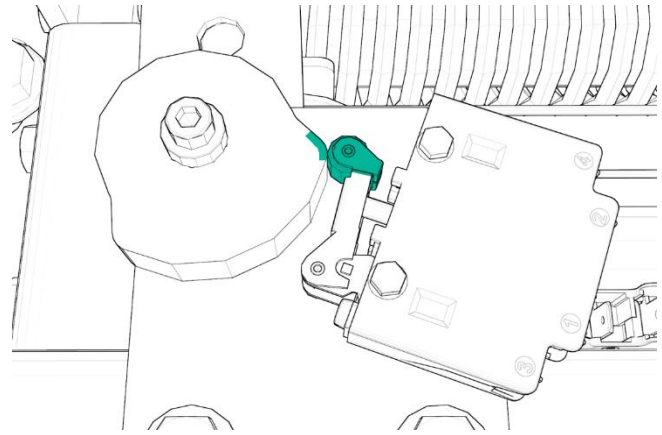

Figure 10: Adjusting micro switch closed position

- Place the 8mm side of the adjustment tool between the door mechanism and the end stopper. (see image) Be aware of pinch point hazard.
- Close the door
- Check if the micro switch closed position activates. The micro switch should NOT be activated.
- If the micro switch activates redo the previous steps.

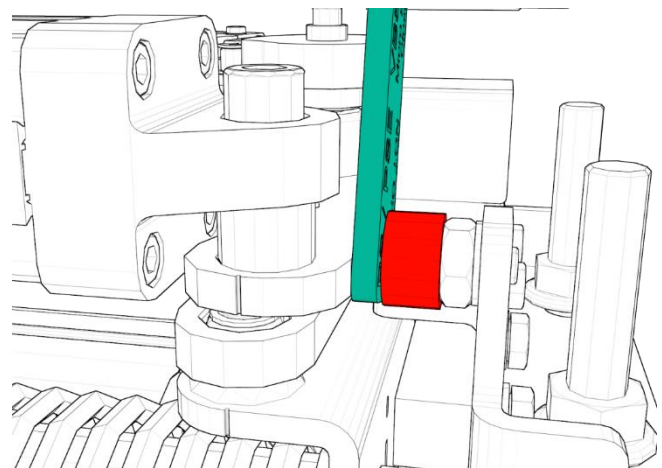

Figure 11: Position 8mm adjustment tool



WARNING!

Remove the power and/or pressure from the system after executing these steps and before you continue.

3.2 Wear parts

These parts wear out and must be replaced when damaged, worn, after the prescribed cycles or after the prescribed time the parts are in usage. When a part has an amount of maximum cycles, it will be mentioned.

3.2.1 Spindle Nut

This step is only applicable for electric systems.

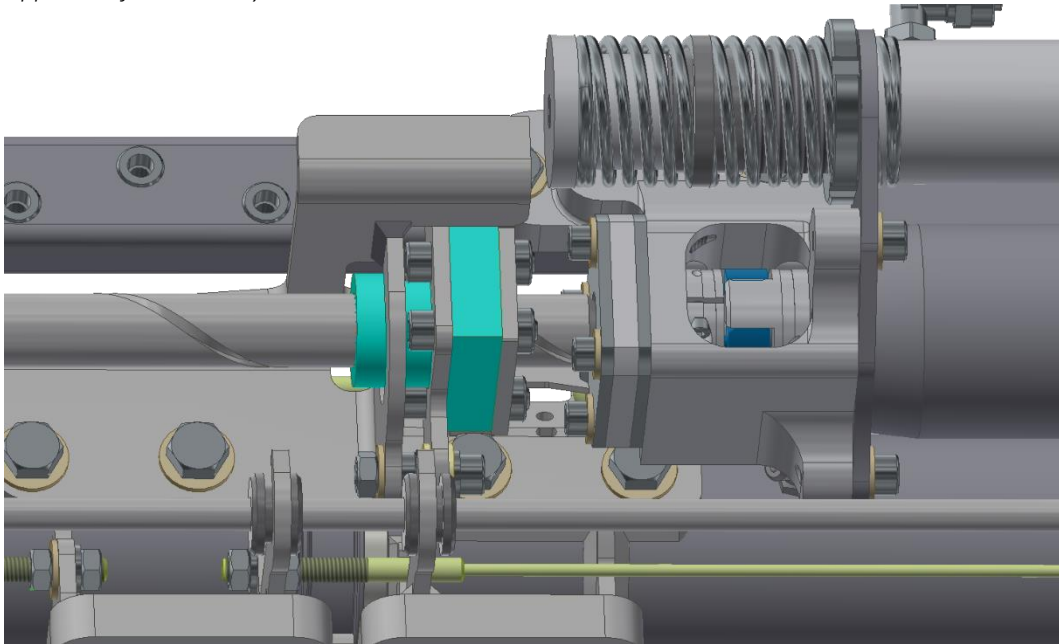

Figure 12: Spindle nut

1. There is no play between the spindle and spindle nut.
To test this, manually twist the spindle.
2. There is no grease or dirt on the spindle, nor the spindle nut.

3.2.2 Over center soft stopper

Apply power and/or pressure to the system and put the doors in closed position.



CAUTION!

Be aware the system could move when applying power and/or pressure to the system.

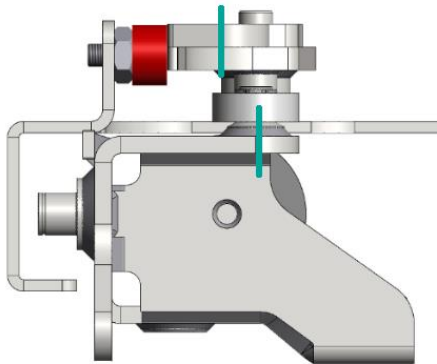

Figure 13: Overcenter electric with unlock cylinder

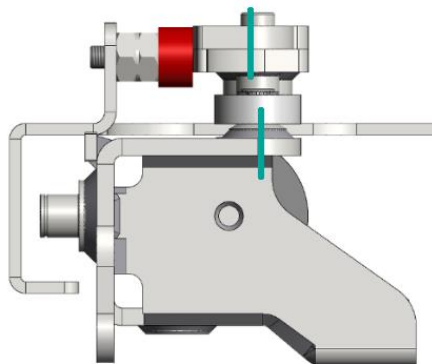

Figure 14: Overcenter pneumatic with unlock cylinder

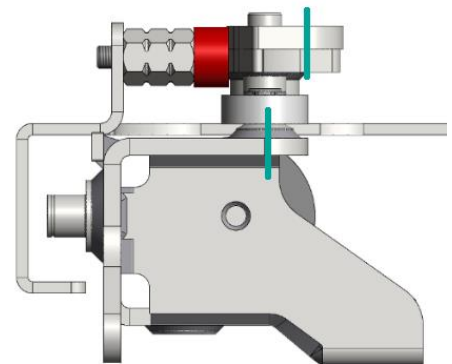

Figure 15: Pneumatic without overcenter function

1. The lever touches the soft stopper in closed position, with power/pressure.
2. The rubber bush of the soft stopper is not worn. Inner dimension following system drawing.



WARNING!

Remove the power and/or pressure from the system after executing this step and before you continue.

3.2.3 Cushioning rubber bearing house

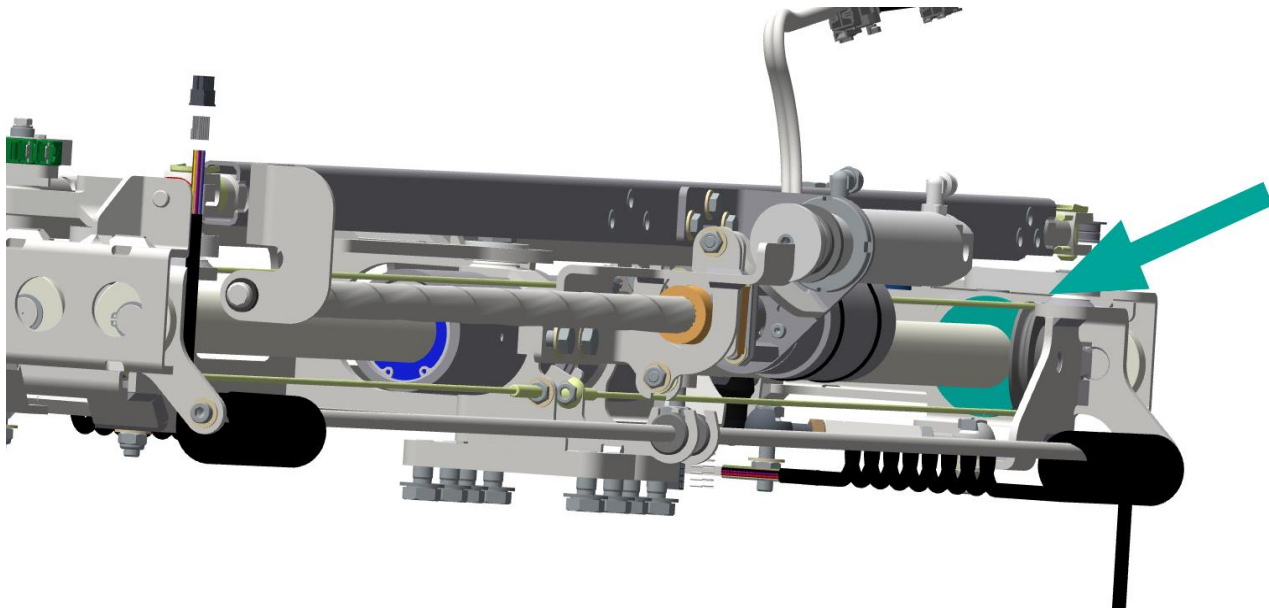

Figure 16: Rubber cushioning ring

1. The cushioning rubber is present at both sides of the mechanism.
2. There is no visible damage on the cushioning rubber.

3.2.4 Guide rollers

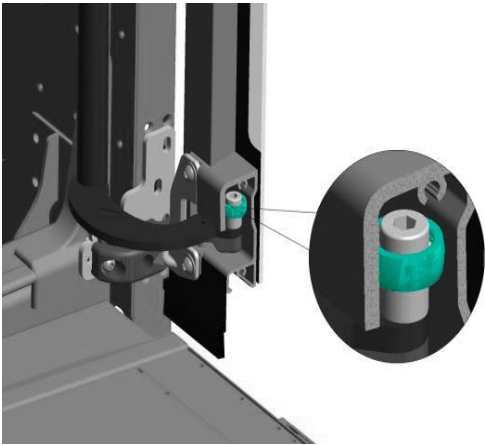

Figure 17: Bottom guide roller

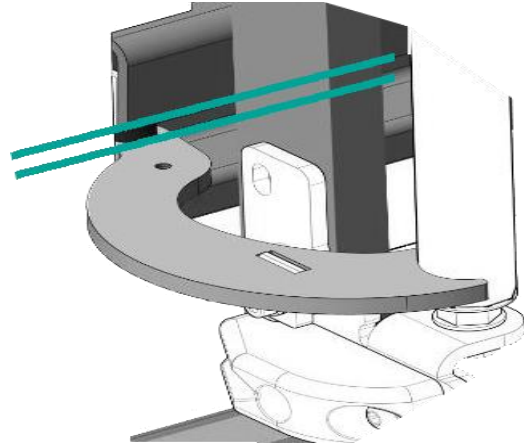

Figure 18: Distance between bottom lever and guiding rail

1. The guide rollers on the lever(s) are not worn or damaged in any way. Check for damage visually and feel if there are no worn places on the guide rollers.
The guide rollers are located at the bottom lever. See image above.
2. The clearance between the bottom lever and the guiding rail is the same as described in the installation manual over the full length of the door movement.
If the clearance is not the same, adjust the height of the door shaft following the installation manual.

3.2.5 Catch block

Apply power and/or pressure to the system and put the door(s) in closed position.



CAUTION!

Be aware the system could move when applying power and/or pressure to the system.



Figure 19: Catch wedge and catch block locations



Figure 20: Check catch wedge

1. Check if the catch wedge is caught by the catch block when the door is closed.
2. The catch block or catch wedge is not worn or damaged.



WARNING!

Remove the power and/or pressure from the system after executing this step and before you continue.

3.2.6 Bottom stopper

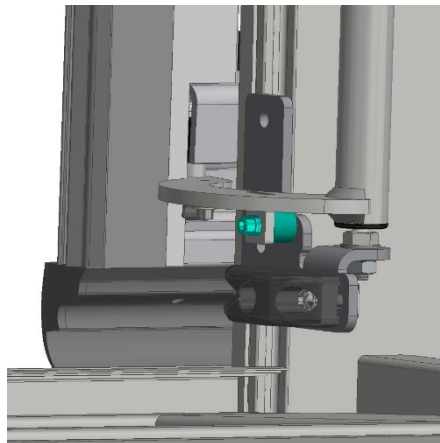

Figure 21: Bottom stopper

1. Check if the bottom stopper is present.
2. The bottom stopper is not worn or damaged.

3.3 Parts inspections

These parts can get affected by usage and must be re-adjusted or cleaned when needed. Check the distance settings of the door system in open and closed position following the installation manual. Check the torque settings of the door system following the installation manual.

3.3.1 Door shafts

- Check if the door shaft is free from vertical play (up and downward movement).

If the door shaft is free from vertical play, continue without executing this step. If there is play, execute the following checks.

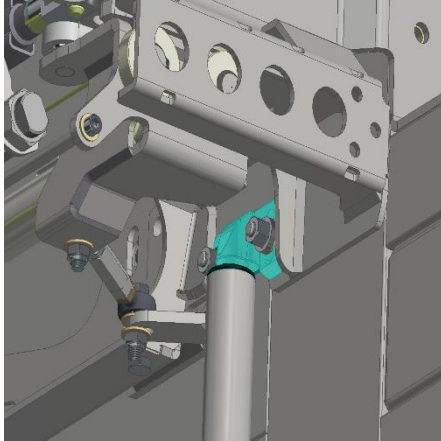

Figure 22: Top bearing door shaft

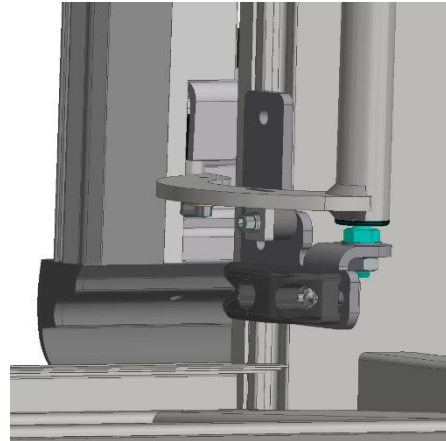

Figure 23: Bottom bearing door shaft

1. Check the settings following the installation manual.
2. The bearing bush and pivot point at the bottom of the door shaft are not worn or damaged.
3. The bearing bush and pivot point at the top of the door shaft is not worn or damaged.

3.3.2 Filter regulator

Check if the system is equipped with a regulator or a filter regulator. If there is no regulator or a filter regulator, skip this step.

1. Check if the pressure of the pneumatic system is 8* bar.
*in case of an electric system with a non-Ventura DCU,
check if the pressure of the pneumatic system is 6 bar.
2. The Camozzi filter regulator is semi-automatic, meaning the filter will drain itself when the pneumatic pressure drops below 0.3 bar (4.3 PSI) and the drain is open.
3. Replace the filter when it is not clear white.

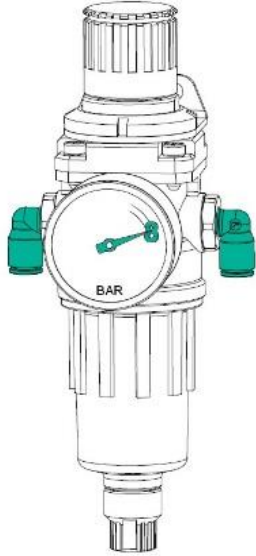

Figure 24: Camozzi filter regulator

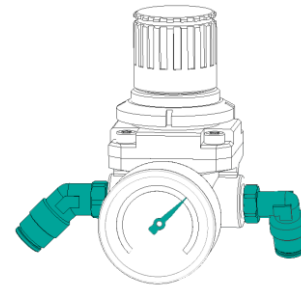

Figure 25: Camozzi regulator

Open drain by turning clockwise
Close drain by turning counter clockwise

NOTICE

Depending on the filter regulators location, it is advised to keep the drain closed so it will not spill dirt over vital parts of the bus.

3.3.3 Tension steel cables

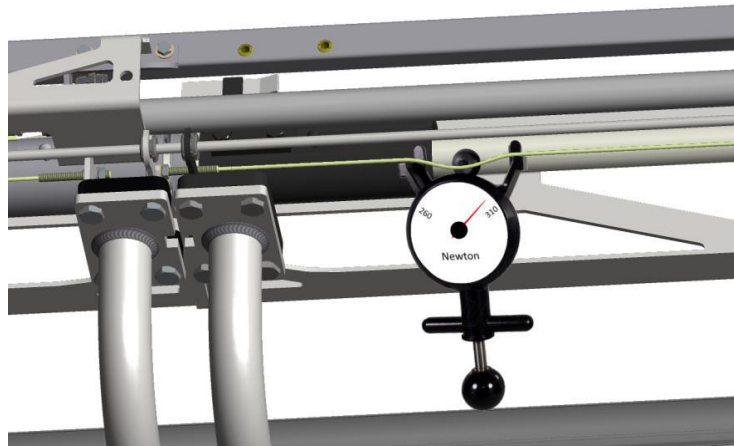

Figure 26: Tension meter

- Put the doors in open position.
- Apply the tension meter as described by the manufacturer.
 1. Check if the tension in the cable is 260-310 Newton.
 2. When using a sonic tension meter, the tension has to be 33-39 hertz.

3.3.4 Clamping force test

Be assured all safety features of the system are active. Execute the obstruction test following the applicable regulations for your company. (Regulations Ventura meets are REG107, TS155 or APTA)

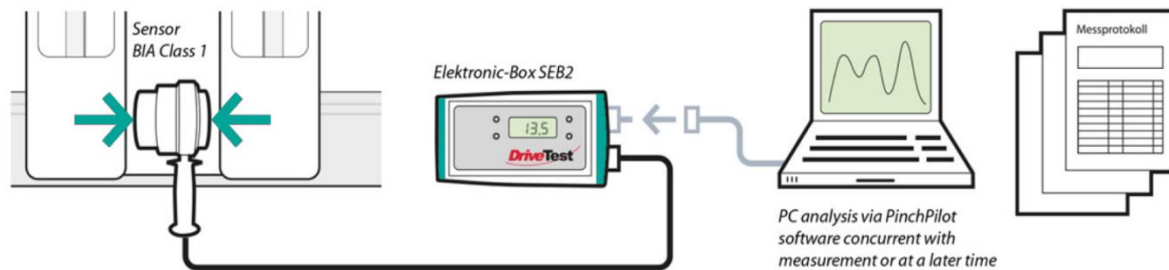

Figure 27: Obstruction test setup

1. Setup the measurement system following the user manual included with the measurement tool.
2. Apply power and/or pressure to the system.



CAUTION!

Be aware the system could move when applying power and/or pressure to the system.

3. Put the doors in open position.
4. Execute the test according to the applicable regulations.

When the test is not successful;

- Check the safety parts of system.
- Check adjustments following the installation manual.



WARNING!

Remove the power and/or pressure from the system after executing this step and before you continue.

3.3.5 Grease bearing house

The bearing house is greased before delivery. In some cases the bearing house needs a refill.
(Use "Arcanol MULTITOP" or a grease with similar specifications)

NOTICE

If a refill is needed with grease, do not use more as 20gr. When the bearing house has too much grease, the friction will hinder a smooth opening and closing of the door system.

1. The bearing houses run silent and smoothly over the guiding shaft.
2. If there is thin grease on the guiding shaft. The grease could be refilled.

3.3.6 Grease spiral cable guiding shaft

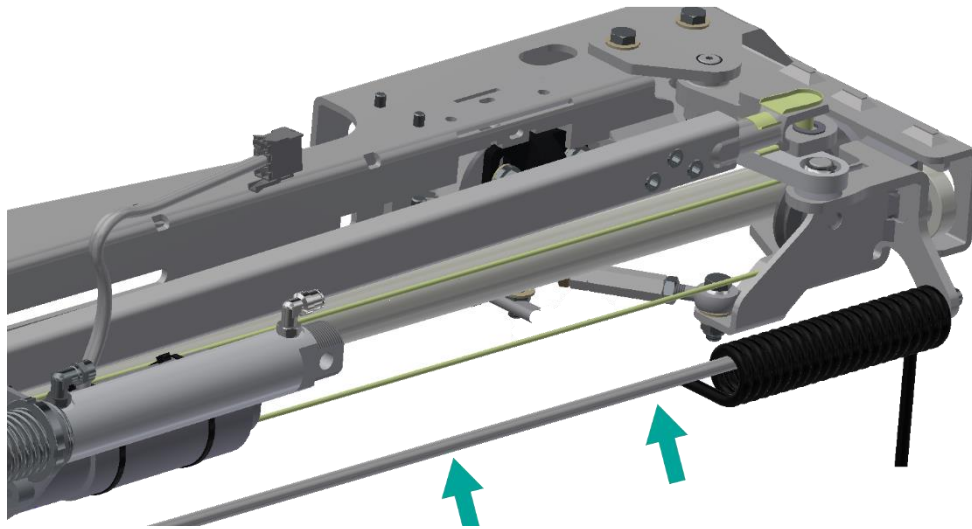

Figure 28: Spiral cable guiding shaft

- Put the doors in open position.
 1. The shaft is clean of dirt.
 2. There is a layer of grease on the guiding shaft which helps the spiral cable run smoothly over the shaft.
- Apply grease when needed. (Use "Kroon Multi Purpose Lithep EP2" or a grease with similar specifications)

4 Torque Settings

All generic plug slide settings that require torque tightening are in this chapter. Check all mentioned fasteners on the correct torque settings. In case of a double leaf system, check both sides.

The fasteners which connect Ventura parts onto the vehicle are, in most cases, non-Ventura parts. Therefore the torque of these fasteners is not defined by Ventura.

After setting a part to torque specification, mark the connection with a torque marker.

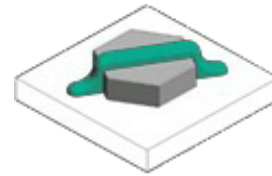

Figure 29: mark the fasteners with a torque marker.

The position in the system overview have details in the following part of this manual. In the second part the torque settings are described.

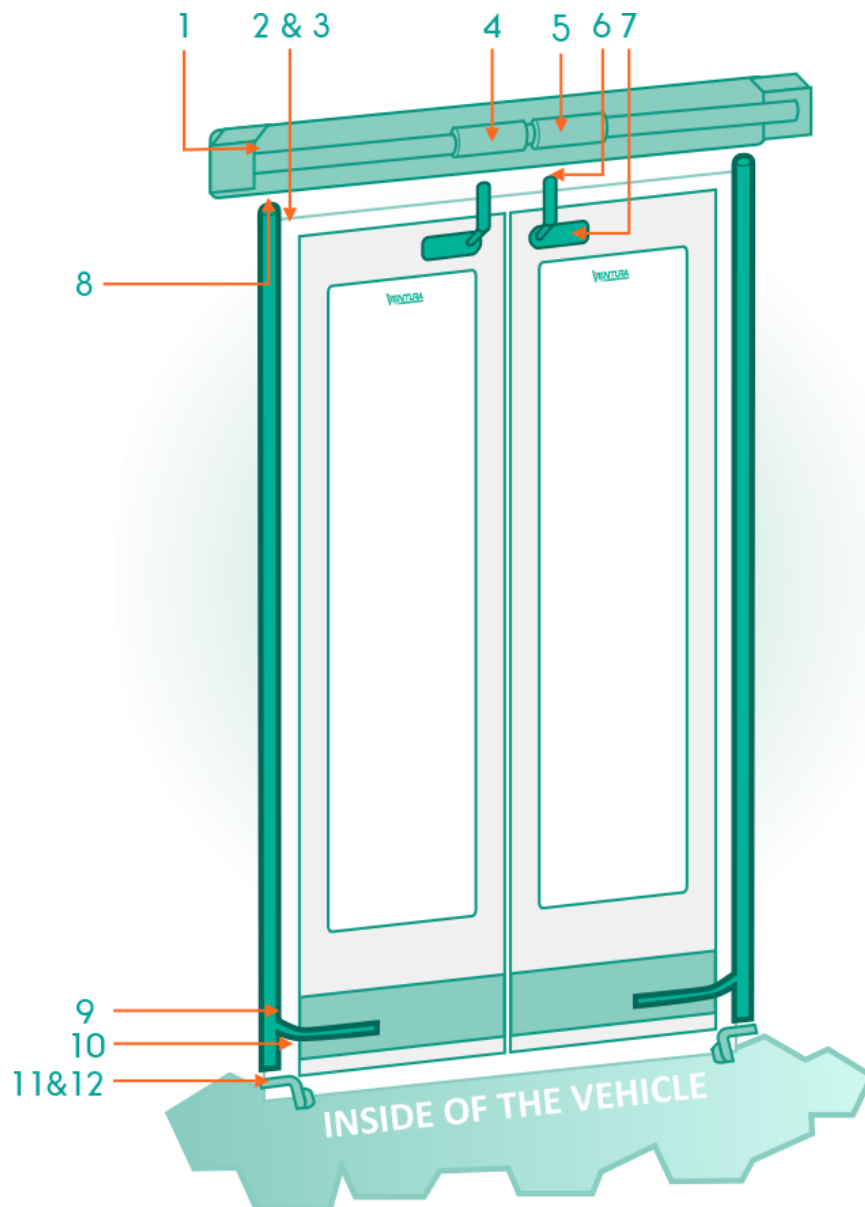
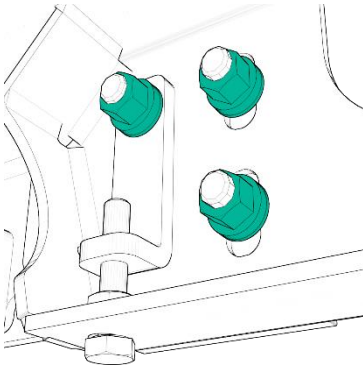

Figure 30: torque setting overview.

Position 1



45±4 Nm, 3 per side

Position 2

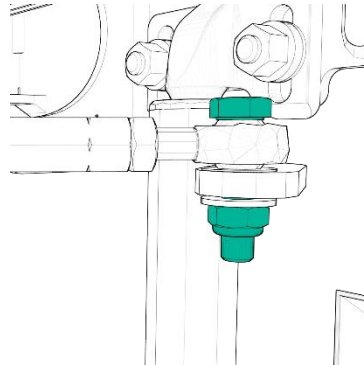

22±2 Nm, 2 per side

Position 3

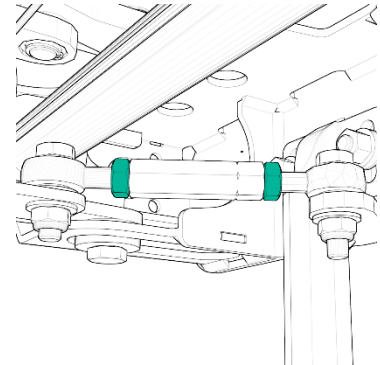

13±1 Nm, 2 per side

Position 4

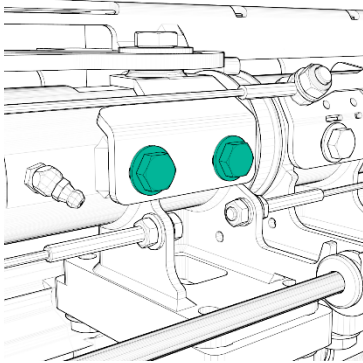

22±2 Nm, 3pc

Position 5

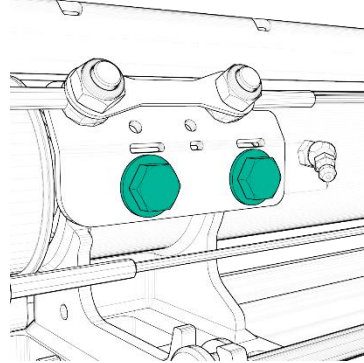

22±2 Nm, 2pc

Position 6

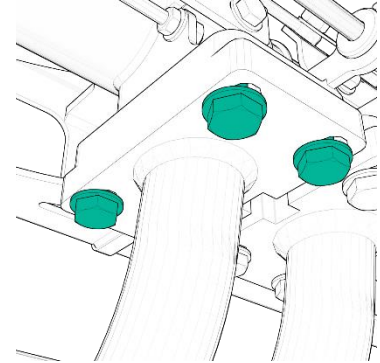

45±4 Nm, 4 per side

Position 7

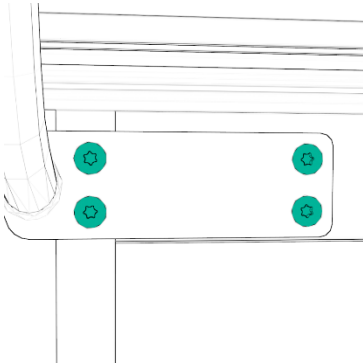

59±5 Nm, 4 per side

Position 8

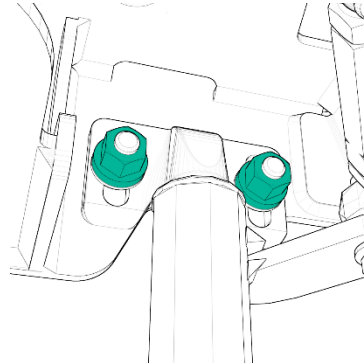

22±2 Nm, 2 per side

Position 9

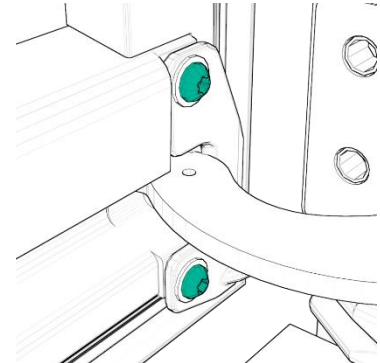

26±2 Nm, 2 per side

Position 10

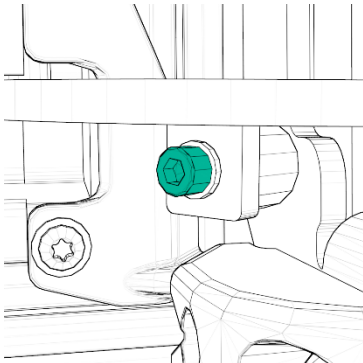

9±1 Nm, 1 per side

Position 11

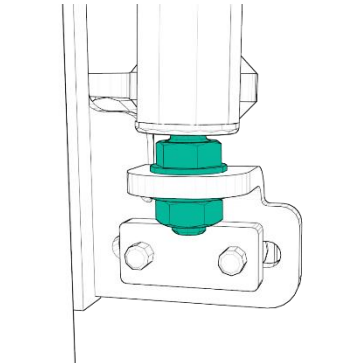

45±4 Nm, 1 per side

Position 12

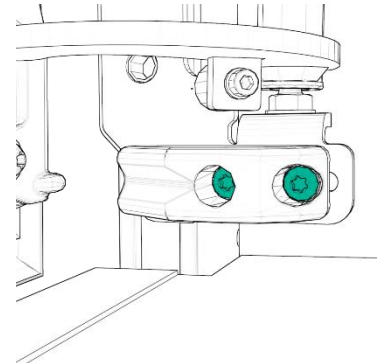

26±2 Nm, 2 per side

5 Operational checks

Execute these checks before applying power.



WARNING!

Applying power to an unchecked system may result in a potentially hazardous situation which, if not avoided, could result in death or serious injury.

No.	Check	Verified by	Approved
1.	Be assured all fasteners are on torque as described in the installation manual of this system.		
2.	Check if no cables/tubes are loose on the system.		
3.	Check if all parts are in place.		
4.	Manually check if the door leaf/leaves open and close without obstructions.		
5.	All safety parts are connected.		

After these checks, the power may be applied.

5.1 Operation and controls

These checks are all with power and/or pressure.

No.	Check	Verified by	Approved
1.	In case of Pneumatic parts: There is no leakage in the pneumatic system. Also, no leakage while opening and closing the doors.		
2.	In case of electric parts: Check if the electric parts and wires has no short circuits or damages.		
3.	Check if all settings match the installation manual.		

5.2 Safety checks

These checks are all with power and/or pressure.

No.	Check	Verified by	Approved
1.	All emergency buttons are functioning.		
2.	Check pneumatic obstruction detections. (if applicable)		
3.	Apply an obstruction while closing. Doors open again. Test left and right separately. *CAUTION!		
4.	Apply an obstruction while opening. Doors go to half open position. Test left and right separately. (if applicable) *CAUTION!		
5.	Check if the mechanism goes overcenter in closed position. (if applicable)		



CAUTION!

Do not use body parts to apply an obstruction.

6 Contact

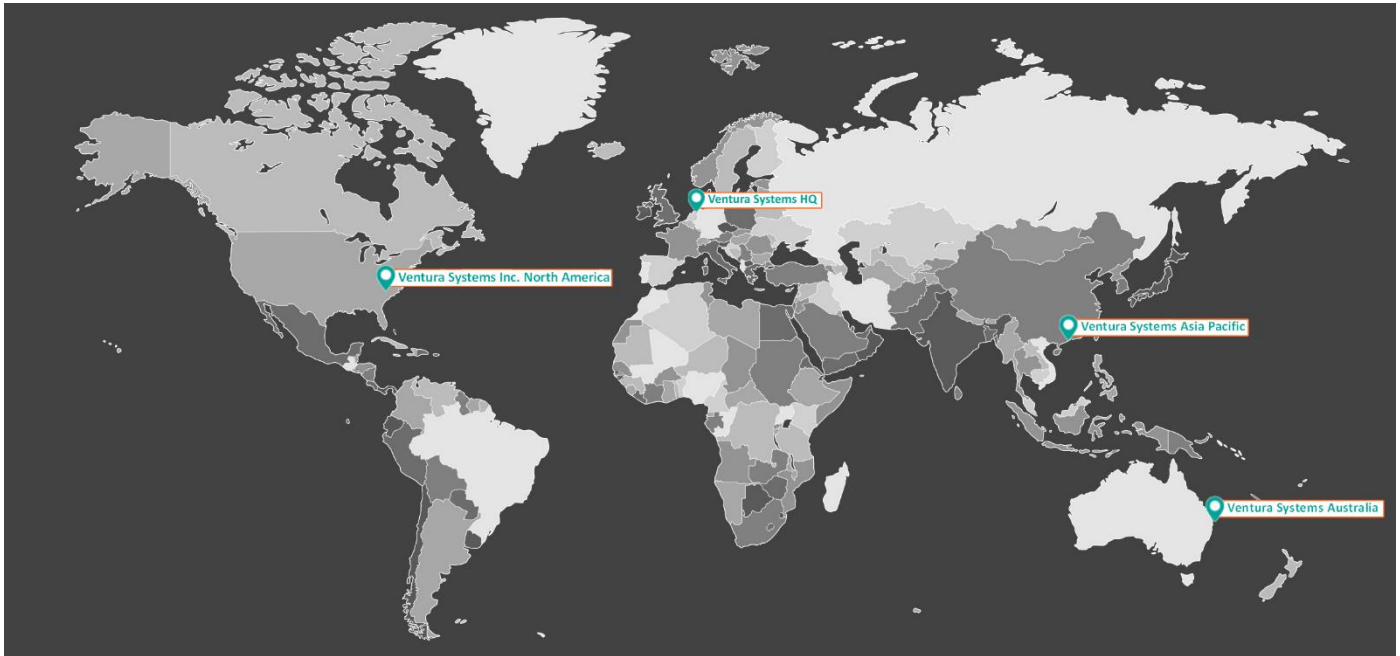

Figure 31: World map Ventura locations





Ventura Systems HQ	Ventura Systems Asia Pacific	Ventura Systems Australia	Ventura Systems Inc North America
 De Marne 216 8701MH Bolsward The Netherlands	Unit 02 on the 11/F Fotan Industrial Centre 26-28 Au Pui Wan Street Hong Kong	PO Box 284 Sanctuary Cove QLD 4212 Australia	160 Gibson Ct NC 28034 Dallas
 +31 (0) 51 557 7750	+852 2712 6001		+1 704-691-0311
 +31 (0) 51 557 3410	+852 2512 2325		+1 704-691-0313
 service@venturasystems.nl	info@venturasystems.hk	info@venturasystems.com.au	info@venturasystems.com
 www.venturasystems.nl			

Table 6: General contact information



Ventura Systems HQ	Ventura Systems Asia Pacific	Ventura Systems Australia	Ventura Systems Inc North America
 parts@venturasystems.nl	info@venturasystems.hk	info@venturasystems.com.au	info@venturasystems.com
 +31 (0) 515 577485			

Table 7: Parts contact information

Contact your local Agent for parts.