

Rotary Lock Handle: Has been modified so lock can not be engaged from inside vehicle but can be disengaged if locked or engaged from outside.

1. TO LOCK DOOR: FROM OUTSIDE

With door in fully closed position and key slot in a horizontal position rotate handle **Anti-clockwise**. This will extend lock pin and lock door, handle will then spring return to a vertical position. Place key in lock then turn key only **90° Anti-clockwise** to a vertical position and remove key. This will lock and prevent handle from rotating from outside...

2. TO UNLOCK DOOR: FROM OUTSIDE

Place key in lock then turn key only **90° Clockwise** to a horizontal position and remove key, Now turn rotary handle **Clockwise**, this will retract lock pin and unlock door. Rotary handle will then spring return to a vertical position. Door can now be power operated or manually pushed open from outside or pulled open from inside

3. TO MANUALLY OPEN DOOR FROM OUTSIDE (ONLY WHEN DOOR IS UNLOCKED)

To unlock door as in item.2
Push door on left hand side, this will disengage slide clutch.
With door open slightly, Push left side and pull right side door into a fully open position.

4. TO MANUALLY OPEN DOOR FROM INSIDE (ONLY WHEN DOOR IS UNLOCKED)

Push door on left hand side & Pull from right side using **BLACK** internal pull handle, This will disengage slide clutch and you will be able to open door fully.

5. TO MANUALLY CLOSE DOOR IF MANUALLY OPENED

Pull & push door to full close position snapping slide clutch into its engaged position, which should be heard. Now door can be locked as in item.1

6. TO OPEN DOOR IN A EMERGENCY FROM INSIDE WHEN DOOR LOCK IS ENGAGED

With the door closed and lock pin engaged (may be key locked too), Door can be opened manually from inside the vehicle, by using the **"LOCK OVERRIDE"** round handle. Rotating handle **Anti-clockwise**, This will retract lock pin and release door, for manual open from inside & outside or power operation to open.

7. Rotary handle lock key can be removed In two positions when handle is locked & unlocked.

IMPORTANT NOTE: BEFORE POWERING UP VEHICLE

With **NO** power supply to door drive system and open/close control buttons, with rotary handle unlocked and lock pin disengaged.

- A . Manually open by means of Push/Pull action, the door then must be manually closed after entering vehicle to engage slide clutch correctly. Now **POWER** up vehicle and door can be operated normally by the drivers & remote control buttons
- B . Door cannot be shut manually with door powered to fully open position.
- C . Door **must** not be power operated when lock pin is engaged or extended

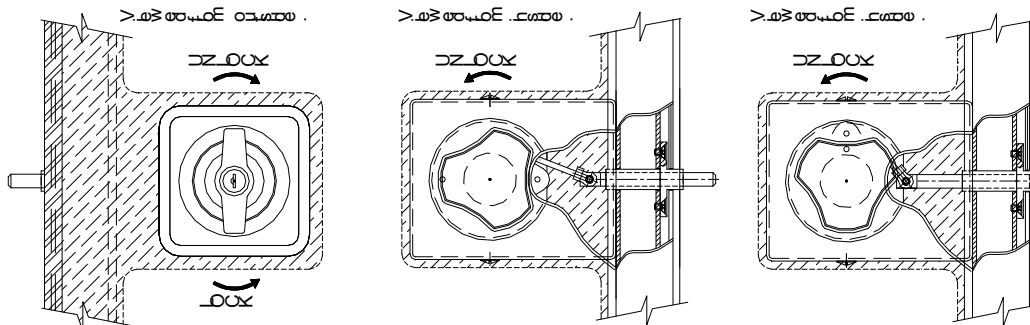

BLACK
Internal Pull handle