

BASIC DOOR SYSTEM CHECK GUIDELINES

Mellor Maxima/Strata HF : RH Single Glider 12v Electric Door System GLD069 & 072

These doors are designed for ease of use and operation. The amount of moving parts has been kept to an absolute minimum, thus reducing the levels of maintenance required. The following guidelines are our recommended minimum level of service / inspection.

Service-Inspection Time Guide: 1st Check at 6 months then annually thereafter or when replacing a defective/damaged part.

It is important that any components found to be damaged or defective at any time are replaced or repaired as soon as possible. Failure to do so could result in further damage to other components or loss of door operation.

- Manually open and close the door via slide clutch,
 - Checking that door is free running.
 - Ensure that Aperture seals, Nosing rubber, Door active flaps & Bottom guide pin are not restricting door movement.
 - Checking slide clutch is engaging with door in the fully closed position against aperture seals.
 - Adjust spring tension to suit operation if required (see details for standard setting).
- Check door-guide roller/spindle for clearance gap (3mm) and free movement in the integral track on underside of shelf-plate are dry and free from grease and the spindle is fully secured correctly.
- Check that all fasteners and bolts on door-leaves and shelf-plate are fully secured.
- Check all electrical connections, ensure cables are not snagging when manually opening door.
- Visually check all aperture seals, door frame & nosing rubber, handles, door-shaft, for any damage and are secured correctly.
- Pivot & Bearings **Lubrication** as required.
- Check full function of lock system and **Lubrication** as required.

= Denotes Grease Lubrication. AC (Blue)Corrosion Block high performance Grease or K2EP (Red)Morris long life grease

= Denotes Lubrication. Use AC90 or WD Dry chain lub

(Do Not Use WD40 Original for lubrication only use as cleaning agent)

- Inner Sabot Cover:** To remove cover pop out plastic screw caps, using poz bit screw driver, slacking off screws, then pull up cover vertically to remove.

WITH POWER SUPPLY ON

- Operate the doors to check door alignment also with the door in the fully closed position against aperture seals and Door is fully open in a firm position. Adjust if necessary. (Note door guide spindle must be in the vertical position)
- Check the operation of the door using all open and close buttons located in the drivers console, above the doors and those positioned externally and hand brake interlock (auto close)
- Check reed-switch positions, with door closed and open position Adjust if necessary, with slide clutch fully engaged.
- Check step light active when operating door either by Manually or Electric drive method to fully open door.

Door guide Spindle & Door guide Bracket
2-3mm Clearance

Horizontal Brush Seal

Upper Pivot Bearing

Door Serial No.

Grab handle

Trailing Edge & Rear Rubber

RH Door-shaft

Vertical Aperture Rubber seal

External Open/Close Button

Leading Edge & Nosing Rubber

Inner Sabot Cover

Bottom Bearing Behind door

RH Descending Handrail

Internal Rotary Lock

External Rotary Lock

Lower Pivot Bearing
or **Slide Rail (light lubrication)**

"E" Drive Unit Assy

Door Closed Reed Switch

Door Open Reed Switch

To remove "E-Drive Unit Assy".
Mark up all plugs with matching No# then disconnect. Manually half open door, remove # circlip & M16 washer from rear end then remove # M12 nut & washer from front end, lift off drive and remove for further inspection or replacement as required.

Circlip & M16 washer

Slide Clutch Warning micro-switch

M12 Hex Nut

Drive Crank Arm

Shaft Top Bearing

Spherical Rod End

5mm Min When Door Is Fully Closed

Clutch Spring Setting

1. Electric Drive=15mm(+1.5 -0.0)
2. Manual Drive=11mm (+/- 1.0)

Check For Grease on Slide clutch arm

External Rotary Lock. For fully operating details see instruction sheet HDL039T-J2-02

SAFETY NOTE: Before any checks are undertaken you may need to turn the power supply off to the door system via the circuit breaker switch if applicable. First, Position door in the fully closed position.

Roatary Lock Handle:Has been modified so lock can not be engaged from inside vehicle but can be disengaged if locked or engaged from outside.

1. TO LOCK DOOR: FROM OUTSIDE

With door in fully closed position and key slot in a horizontal position rotate handle **Anti-clockwise**. This will extend lock pin and lock door, handle will then spring return to a vertical position. Place key in lock then turn key only **90° Anti-clockwise** to a vertical position and remove key. This will lock and prevent handle from rotating from outside...

2. TO UNLOCK DOOR: FROM OUTSIDE

Place key in lock then turn key only **90° Clockwise** to a horizontal position and remove key, Now turn rotary handle **Clockwise**, this will retract lock pin and unlock door. Rotary handle will then spring return to a vertical position. Door can now be power operated or manually pushed open from outside or pulled open from inside

3. TO MANUALLY OPEN DOOR FROM OUTSIDE (ONLY WHEN DOOR IS UNLOCKED)

To unlock door as in item.2
Push door on left hand side, this will disengage slide clutch.
With door open slightly, Push left side and pull right side door into a fully open position.

4. TO MANUALLY OPEN DOOR FROM INSIDE (ONLY WHEN DOOR IS UNLOCKED)

Push door on left hand side & Pull from right side using BLACK internal pull handle, This will disengage slide clutch and you will be able to open door fully.

5. TO MANUALLY CLOSE DOOR IF MANUALLY OPENED

Pull & push door to full close position snapping slide clutch into its engaged position, which should be heard. Now door can be locked as in item.1

6. TO OPEN DOOR IN A EMERGENCY FROM INSIDE WHEN DOOR LOCK IS ENGAGED

With the door closed and lock pin engaged (may be key locked too), Door can be opened manually from inside the vehicle, by using the **“LOCK OVERRIDE “** round handle. Rotateing handle **Anti-clockwise**, This will retract lock pin and release door, for manual open from inside & outside or power operation to open.

7. Rotary handle lock key can be removed In two positions when handle is locked & unlocked.

IMPORTANT NOTE: BEFORE POWERING UP VEHICLE

With **NO** power supply to door drive system and open/close control buttons, with rotary handle unlocked and lock pin disengaged.

- A . Manually open by means of Push/Pull action, the door then must be manually closed after entering vehicle to engage slide clutch correctly. Now POWER up vehicle and door can be operated normally by the drivers & remote control buttons
- B . Door cannot be shut manually with door powered to fully open position.
- C . Door **must** not be power operated when lock pin is engaged or extended

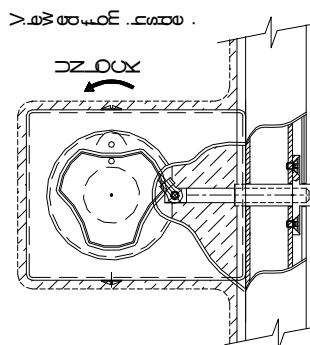
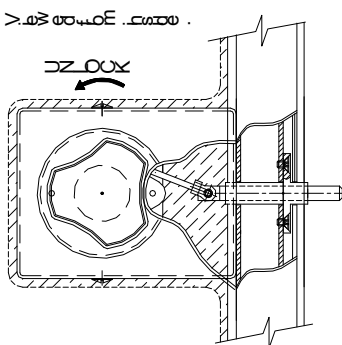
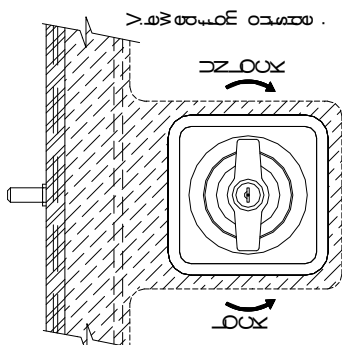

BLACK
Internal Pull handle