



Inward Gliding Door System 4

Maintenance Manual

| | |
|--------------|------------------------------|
| Version | 0.4 |
| Release date | 2018-12-04 |
| Document ID | IG4100001 |
| Project name | Inward Gliding Door System 4 |
| Project ID | IG4 |

We welcome millions
of people every day



Revision history

| Revision | Date | By | Description |
|----------|------------|-------------|---|
| 0.4 | 2018-12-04 | M.Stoelinga | Frequency changed. |
| 0.3 | 2018-11-30 | M.Stoelinga | Frequency changed. Moved "Clamping force test" from "Safety parts" to "Part inspections". Added the sentence: "Contact your local Agent for parts." Adjusted filter regulator check for electric systems with non-Ventura DCU. |
| 0.2 | 2018-11-15 | M.Stoelinga | Rephrased safety checks. Changed reference from appendix to installation manual. Adjusted contact information. |
| 0.1 | 2018-11-13 | M.Stoelinga | Initial version. |



Preface

The Quality System of Ventura Systems is accredited to EN ISO 9001:2015

All rights reserved. Disclosure to third parties of this document or any part thereof, or the use of any information contained therein for purposes other than provided for by this document, is not permitted, except with prior and express written permission from Ventura Systems.

Table of Contents

| | |
|---------------------------------------|----|
| 1 Introduction | 6 |
| 1.1 Purpose | 6 |
| 1.2 Scope | 6 |
| 1.3 Definitions | 6 |
| 1.4 Acronyms and Abbreviations | 6 |
| 1.5 References | 6 |
| 1.5.1 External documents | 6 |
| 1.6 Overview | 6 |
| 2 Door installation safety | 7 |
| 2.1 General | 7 |
| 2.2 Disclaimer | 7 |
| 2.3 Safety alert symbols | 8 |
| 2.4 Safety instructions | 9 |
| 3 Maintenance | 10 |
| 3.1 Safety parts | 10 |
| 3.1.1 Emergency release | 10 |
| 3.1.2 Sensitive edge | 11 |
| 3.2 Wear parts | 12 |
| 3.2.1 Secure nut | 12 |
| 3.2.2 Guide rollers | 13 |
| 3.2.3 Bearing bush shaft | 13 |
| 3.2.4 Bearing bush bottom | 14 |
| 3.2.5 Sliding plate | 14 |
| 3.3 Parts inspections | 15 |
| 3.3.1 Filter regulator | 15 |
| 3.3.2 Clamping force test | 16 |
| 3.3.3 grease spiral cable shaft | 17 |
| 4 Operational checks | 18 |
| 4.1 Operation and controls | 18 |
| 4.2 Safety checks | 18 |
| 5 Contact | 19 |

List of Figures

| | |
|--|----|
| Figure 1: Spiral cable runs smooth and has no overlength | 11 |
| Figure 2: Secure nut with SK ring | 12 |
| Figure 3: Secure nut with Nord-lock | 12 |
| Figure 4: VA3860 Torque Wrench | 12 |
| Figure 5: Guiding shaft | 13 |
| Figure 6: Bottom bearing bush | 13 |
| Figure 7: Lever bearing bush | 14 |
| Figure 8: Sliding plate | 14 |
| Figure 9: Camozzi filter regulator | 15 |
| Figure 10: Obstruction test setup | 16 |
| Figure 11: Spiral cable guiding shaft | 17 |

List of Tables

| | |
|----------------------------|---|
| Table 1: Definitions | 6 |
|----------------------------|---|



| | |
|---|----|
| Table 2: Acronyms and abbreviations | 6 |
| Table 3: External documents | 6 |
| Table 4: Maintenance frequencies | 10 |

1 Introduction

1.1 Purpose

This maintenance manual describes maintenance and small adjustment procedures for the Ventura plug slide door system. Together with the Installation manuals and system drawings makes a complete set of maintenance documentation. It is important to follow all instructions. All instructions must be conducted without air/electric power unless mentioned otherwise. The instructions should be executed for the left and right door leaf when the system contains two door leaves. A well-adjusted door system is less vulnerable to failure. The right maintenance is crucial for the durability of the door system.

1.2 Scope

The purpose of this document is to guide trained service mechanics through the maintenance steps of the plug slide door system. When repairs have to be made, the mechanic needs to use the repair manual, or the proper service instruction.

1.3 Definitions

| Definition | Description |
|-------------|---|
| Wear part | Wear is progressive damage to a part caused by relative motion with respect to another substance or part. |
| Safety part | A safety part is a part, which is important to the overall safety of a system. |

Table 1: Definitions

1.4 Acronyms and Abbreviations

| Abbreviation | Description |
|--------------|--|
| ISO | International Standardization Organization |
| HQ | Headquarters |

Table 2: Acronyms and abbreviations

1.5 References

1.5.1 External documents

| Reference | Description | Date |
|---------------|---|------------|
| ISO 9001:2015 | ISO Standard for Quality Management Systems – Requirements. | 2015-10-01 |

Table 3: External documents

1.6 Overview

Section 1 gives an introduction, definitions and overview of this document.
Section 2 contains the general door system safety instructions, safety symbols and disclaimer.
Section 3 contains the maintenance instructions.

2 Door installation safety

2.1 General

Safety of the operator and bystanders is one of the main concerns in designing and developing a new piece of equipment. Ventura's door systems have the proper safety features for common use of the system. An accident can often be avoided by recognizing potentially hazardous situations before an accident occurs. As you install, operate, or maintain the door system, you must be alert to potential hazards. Make sure you have the necessary training, skills and tools to perform any assembly, or maintenance procedures. Improper operation and maintenance of this door system may result in a dangerous situation that may cause injury or death.

Ventura Systems cannot anticipate every possible circumstance that may involve a potential hazard. The warnings in this manual and on the product are not all-inclusive. If a method of installation or operation is used, which is not specifically recommended by Ventura Systems, you must satisfy yourself that it is safe for you and for others. You should also ensure that the door system will not be damaged or be made unsafe by the installation and/or operational methods you choose. The information, specifications and illustrations in this manual are based on the information that was available at the time this manual was written and can change at any time without notice.

2.2 Disclaimer

The information contained in this maintenance manual is based upon reliable technical data at the time the manual was published. These instructions are intended for use by persons having the technical knowledge to maintain this door system. The instructions are to be used at the maintenance mechanic's own discretion and risk. Ventura Systems assumes no responsibility for results obtained or damage incurred from the use of this material either in whole or in part by the installer. This manual provides basic instructions for the maintenance of the door system in a step-by-step sequence that will work in most types of maintenances. While effort has been made to ensure the information in this manual is correct and complete, we would appreciate it if you would contact us in case of errors.

2.3 Safety alert symbols

This manual contains safety messages which alert you to potential personal injury hazards. Obey all safety messages in this manual to avoid possible injury or death. The following key words and layouts calls for your attention: DANGER, WARNING, CAUTION and NOTICE. Below are examples of every safety message. The NOTE message is used for additional information but these are not threatening for the mechanic, bystanders, nor the door system.



DANGER!

Indicates an imminently hazardous situation which, if not avoided, will result in death or serious injury. This signal word is limited to the most extreme situations.



WARNING!

Indicates a potentially hazardous situation which, if not avoided, could result in death or serious injury.



CAUTION!

Indicates a potentially hazardous situation which if not avoided, may result in minor or moderate injury.

NOTICE

Indicates that equipment or property damage can result if instructions are not followed.

NOTE

Additional information important but not threatening for people or to the system.

2.4 Safety instructions



WARNING!

This door system is designed for a specific application; **DO NOT modify or use this unit for any application other than for which it was designed.**

Door systems operated improperly or by untrained personnel is dangerous. Lack of operation knowledge may cause high risk.

Do not install this door system if it is damaged. If you are in doubt if the door system has a defect, immediately stop the installation and contact Ventura Systems.

Do not connect the door system to air or electric supply during the maintenance process. If the manual states otherwise, follow the manual.

Do not attempt to install the door system under influence of drugs or alcohol.

NOTICE

Do not modify the door system or safety devices. Unauthorized modifications may impair its function and safety.

If equipment has been altered in any way from the original design, Ventura Systems does not accept any liability for injury or warranty.

If replacement of parts is necessary, genuine factory replacement parts must be used to restore the door system to its original specifications.

*always disconnect the air and/or electric power while replacing parts. Safety features may not be active while replacing parts.

Ventura Systems will not accept responsibility for damages as a result of the use of unapproved parts.

While working on the Ventura door systems wear appropriate personal protective equipment. This list may include but is not limited to:

- Protective shoes with slip resistant soles
- Protective goggles, glasses or face shield
- A hard hat

Follow the regional and country laws and safety precautions.

3 Maintenance

Maintenance of a door system should only be performed when the bus is positioned on a flat surface to prevent distortion/twisting of the bus body, which can lead to inaccurate measurements of the portal.

Whenever the amount of cycles is past, we advise to execute the applicable maintenance. At the table below, we address the chapter names.

| Cycles assumption | Minimal maintenance | Applicable for |
|-------------------|---------------------|------------------------------------|
| 75.000 | Every 3 months | Safety parts Operational checks |
| 150.000 | Every 6 months | Wear parts |
| 300.000 | Every 12 months | Parts inspections |

Table 4: Maintenance frequencies

Execute at least the minimal maintenance intervals.

3.1 Safety parts

The checks in this chapter are very important. If these parts are not installed correctly, it can have great consequences for the safety of the system. When the system has two door leaves, the checks must be executed for both sides. Ventura Systems recommend to execute all safety checks every 10 000 cycles of the door system.

3.1.1 Emergency release

Apply power and/or pressure to the system and put the door(s) in closed position.



CAUTION!

Be aware the system could move when applying power and/or pressure to the system.

1. When the system is active, activate the emergency release.
The following events should occur.
 2. The power/pressure is released from the system.
 3. The door(s) can be opened manually.
- Reset the emergency release.
 - Open and close the door(s) using the power source.



WARNING!

Remove the power and/or pressure from the system after executing this step and before you continue.

3.1.2 Sensitive edge

- Press against the right mid seal at a height of 1 meter or less. The doors go to open position.
- Press against the left mid seal at a height of 1 meter or less. The doors go to open position.

When the doors do open in both cases, continue to the next step.

When the door leaves do not open when pressing one of the mid seals perform the following checks. Perform the following steps to disconnect the sensitive edge.

- Pull out the cap at the top of the vertical profile. Be aware to not damage the cable, cap or seal.
- Disconnect the sensitive edge from the spiral cable.
- Set the multimeter to continuity mode and connect the multimeter to the connector of the sensitive edge.



Figure 1: Spiral cable runs smooth and has no overlength

1. Be sure there is no force pressing the mid seal which can activate the sensitive edge. Resistance is $8k2\Omega$ or $1k2\Omega$. on the resistor of the sensitive edge.
2. Apply force onto the mid seal of the door leaf. Resistance is approximately $0. \sim 0 \Omega$

Reconnect the sensitive edge to the spiral cable and perform the following checks.

1. Check if spiral cable moves free on the shaft.
2. Check if all the excess length from the spiral cable is fitted inside the door profile. The spiral cable should be fixed to the guiding shaft bracket with a tie wrap. Be sure there is a little play.
3. Add multipurpose grease on the spiral cable shaft so the cable moves smoothly.(Use "Arcanol MULTITOP" or a grease with similar specifications)

Be aware the sensitive edge could not be working. Do not apply an obstruction before measuring the sensitive edges response.

NOTE

The sensitive edge is malfunctioning when the resistance is infinite. $\infty \Omega$.

3.2 Wear parts

These parts wear out and must be replaced when damaged, worn, after the prescribed cycles or after the prescribed time the parts are in usage. When a part has an amount of maximum cycles, it will be mentioned.

3.2.1 Secure nut

Check if there are one or two rings under the secure nut. Two rings mean the door shaft has a Nord-lock locking disk.

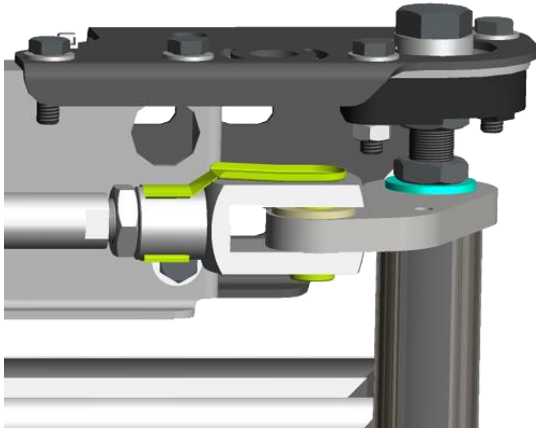

Figure 2: Secure nut with SK ring

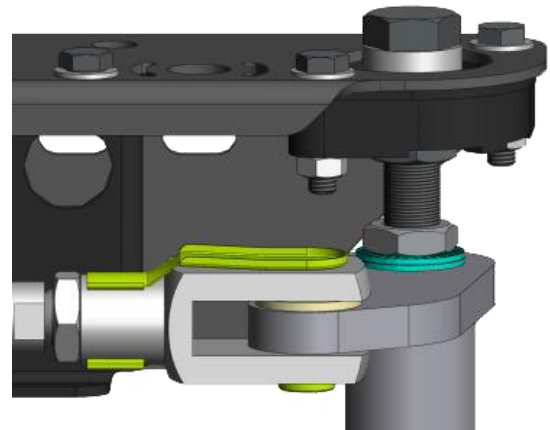

Figure 3: Secure nut with Nord-lock

If the Ventura torque wrench tool is used, read the appropriate documentation of the tool. When the tool is not used follow the options underneath.

1. In case of a Nord-lock ring:
 2. Check if the torque setting of the secure nut is 75Nm.
-
1. In case of SK ring:
 2. Check if the torque setting of the secure nut is 100Nm.

NOTE

If reachability of the secure nut is a problem, use our convenience tool:
- VA3860 Torque Wrench Tool 79.5 (Applicable for all IG4 doors).

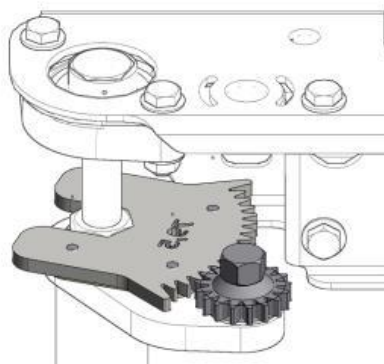

Figure 4: VA3860 Torque Wrench

3.2.2 Guide rollers

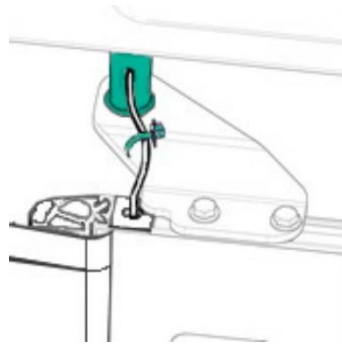

Figure 5: Guiding shaft

1. The guide rollers on top of the guiding shafts are not worn or damaged in any way. Check for damage visually and feel if there are no worn places on the guide rollers.
2. The guide rollers do not press against the guide rail while the doors are opening or closing.

Replace every
100 000
cycles

3.2.3 Bearing bush shaft

- Check if the door shaft is free from vertical play (up and downward movement).
- Check if the door does not squeak. If it does apply some grease between the bearing and bearing bolt.

If the door shaft is free from vertical play, continue without executing this step. If there is play, execute the following checks.



Figure 6: Bottom bearing bush

1. Check if the bottom bearing bush is not broken.

3.2.4 Bearing bush bottom

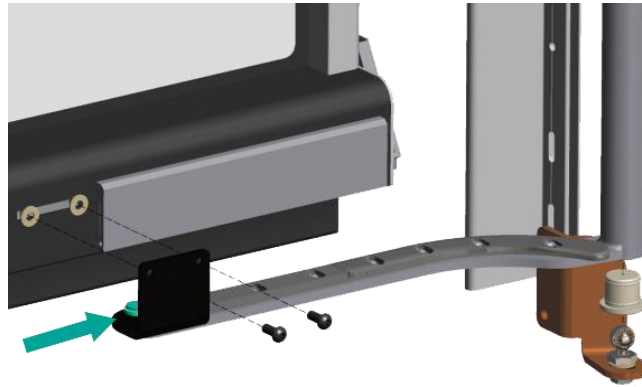

Figure 7: Lever bearing bush

1. Check if the bearing bush on the lever is not broken.
2. Check if the bearing bush on the lever is not blocked by dust and dirt.

3.2.5 Sliding plate

The sliding plate at the bottom lever is not heavily worn.
when the sliding plate is not worn, continue to the next step.

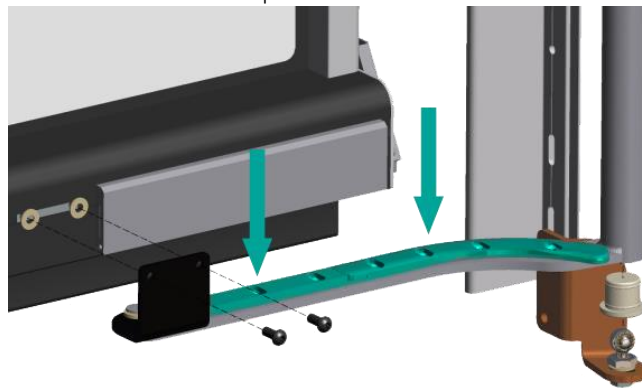

Figure 8: Sliding plate

1. When the sliding plate is worn, replace the part.

3.3 Parts inspections

These parts can get affected by usage and must be re-adjusted or cleaned when needed. Check the distance settings of the door system in open and closed position following the installation manual. Check the torque settings of the door system following the installation manual.

3.3.1 Filter regulator

Check if the system is equipped with a filter regulator. If there is no filter regulator, skip this step.

1. The Camozzi filter regulator is semi-automatic, meaning the filter will drain itself when the pneumatic pressure drops below 0.3 bar (4.3 PSI) and the drain is open.
2. Check if the pressure of the pneumatic system is 8* bar.
*except when the system is electric with a non-Ventura DCU, check if the pressure of the pneumatic system is 6 bar.
3. Replace the filter when it is not clear white.



Figure 9: Camozzi filter regulator

Open drain by turning clockwise
Close drain by turning counter clockwise

NOTICE

Depending on the filter regulators location, it is advised to keep the drain closed so it will not spill dirt over vital parts of the bus.

3.3.2 Clamping force test

Be assured all safety features of the system are active. Execute the obstruction test following REG107.

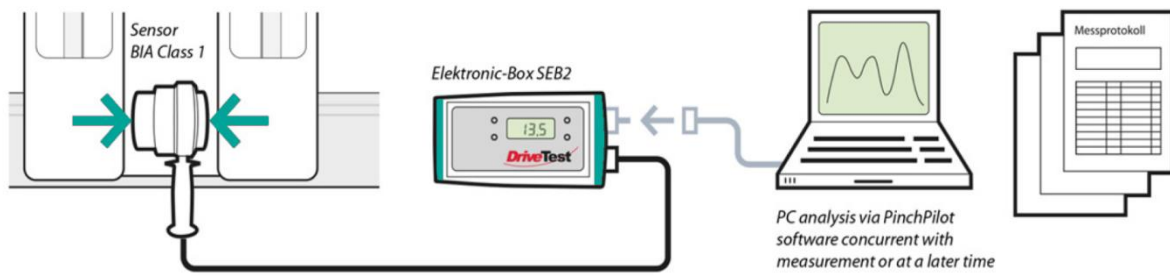

Figure 10: Obstruction test setup

1. Setup the measurement system following the user manual included with the measurement tool.
2. Apply power and/or pressure to the system.



CAUTION!

Be aware the system could move when applying power and/or pressure to the system.

3. Put the doors in open position.
4. Execute the test according REG107

When the test is not successful;

- Check the safety parts of system.
- Check adjustments following the installation manual.



WARNING!

Remove the power and/or pressure from the system after executing this step and before you continue.

3.3.3 grease spiral cable shaft

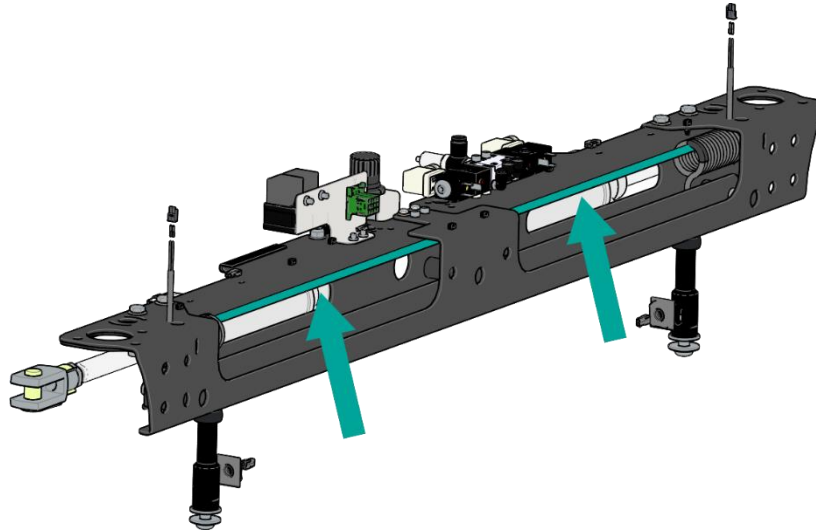

Figure 11: Spiral cable guiding shaft

1. The shaft is clean of dirt.
2. There is a layer of grease on the guiding shaft which helps the spiral cable run smoothly over the shaft.

Apply grease when needed. (Use "Arcanol MULTITOP" or a grease with similar specifications)

4 Operational checks

Execute these checks before applying power.



WARNING!

Applying power to an unchecked system may result in a potentially hazardous situation which, if not avoided, could result in death or serious injury.

| No. | Check | Verified by | Approved |
|-----|--|-------------|----------|
| 1. | Be assured all fasteners are on torque as described in the installation manual of this system. | | |
| 2. | Check if no cables/tubes are loose on the system. | | |
| 3. | Check if all parts are in place. | | |
| 4. | Manually check if the door leaf/leaves open and close without obstructions. | | |
| 5. | All safety parts are connected. | | |

After these checks, the power may be applied.

4.1 Operation and controls

These checks are all with power and/or pressure.

| No. | Check | Verified by | Approved |
|-----|---|-------------|----------|
| 1. | In case of Pneumatic parts: There is no leakage in the pneumatic system. Also no leakage while opening and closing the doors. | | |
| 2. | In case of electric parts: Check if the electric parts and wires has no short circuits or damages. | | |
| 3. | Check if all settings are conform installation manual. | | |

4.2 Safety checks

These checks are all with power and/or pressure.

| No. | Check | Verified by | Approved |
|-----|---|-------------|----------|
| 1. | All emergency buttons are functioning. | | |
| 2. | Check pneumatic obstruction detections (if applicable) | | |
| 3. | Apply an obstruction while closing. Doors open again. Test left and right separately. *CAUTION! | | |
| 4. | Apply an obstruction while opening. Doors go to half open position. Test left and right separately. (if applicable) *CAUTION! | | |





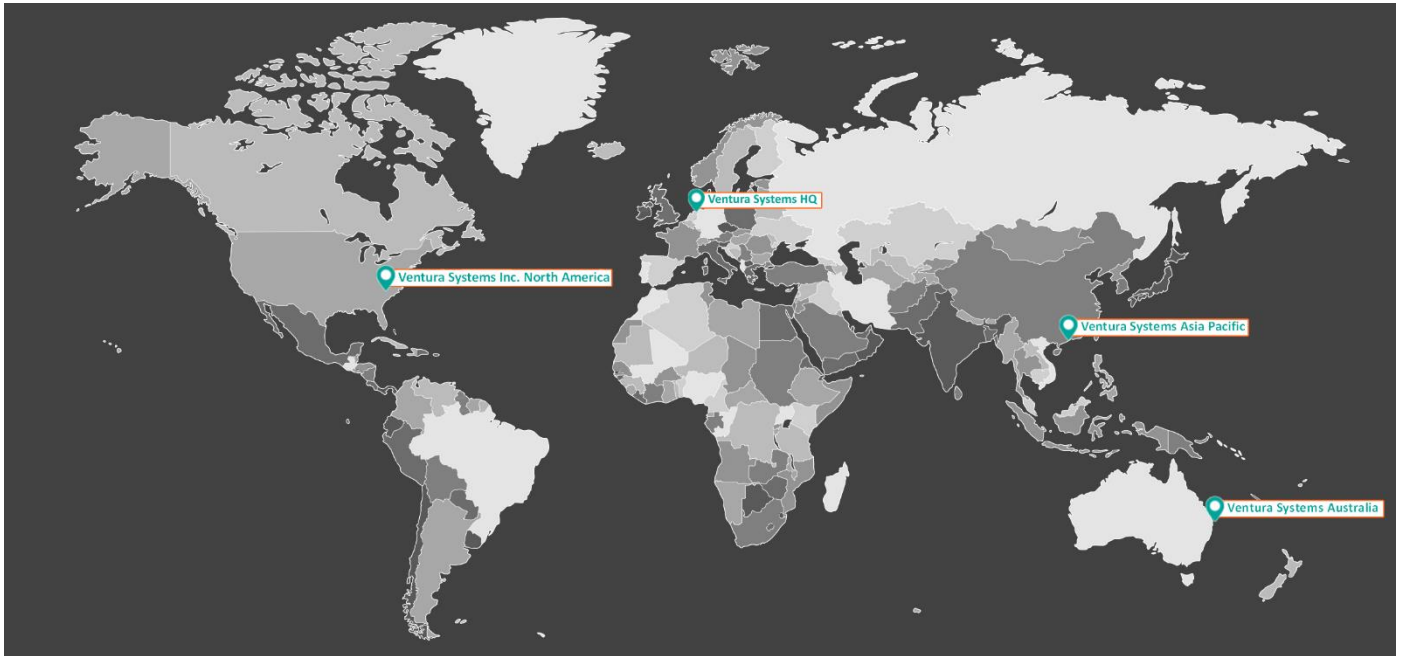

CAUTION!

Do not use body parts to apply an obstruction.



5 Contact



General contact information

| | Ventura Systems HQ | Ventura Systems Asia Pacific | Ventura Systems Australia | Ventura Systems Inc North America |
|---|--|--|--|-------------------------------------|
|  | De Marne 216 8701MH Bolsward The Netherlands | Unit 02 on the 11/F Fotan Industrial Centre 26-28 Au Pui Wan Street Hong Kong | PO Box 284 Sanctuary Cove QLD 4212 Australia | 160 Gibson Ct NC 28034 Dallas |
|  | +31 (0) 51 557 7750 | +852 2712 6001 | | +1 704-691-0311 |
|  | +31 (0) 51 557 3410 | +852 2512 2325 | | +1 704-691-0313 |
|  | service@venturasystems.nl | info@venturasystems.hk | info@venturasystems.com.au | info@venturasystems.com |
|  | www.venturasystems.nl | | | |

Parts contact information

| | Ventura Systems HQ | Ventura Systems Asia Pacific | Ventura Systems Australia | Ventura Systems Inc North America |
|---|-------------------------|------------------------------|----------------------------|-----------------------------------|
|  | parts@venturasystems.nl | info@venturasystems.hk | info@venturasystems.com.au | info@venturasystems.com |
|  | +31 (0) 515 577485 | | | |

Contact your local Agent for parts.