

EPSILON > ELECTRIC DOOR SYSTEM

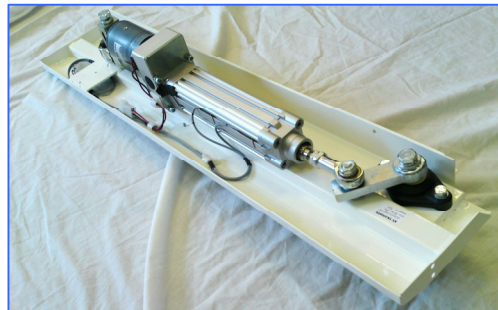
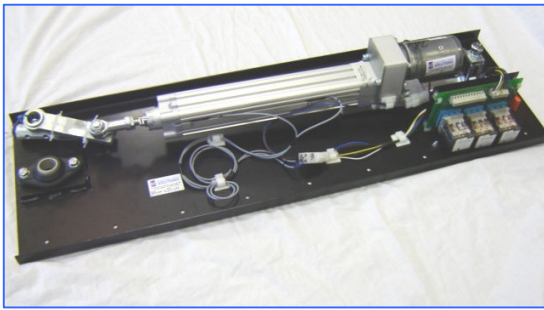
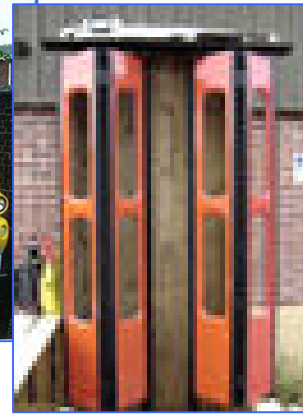

MAINTENANCE MANUAL

CONTACT DETAILS >

43 Broton Drive, Halstead, Essex, CO9 1HB

Tel: 01787 473000

Fax: 01787 477040

Email: sales@transportdoorsolutions.co.uk

Internet: www.transportdoorsolutions.co.uk

INTRODUCTION

Transport Door Solutions door system is a most durable system. By drawing on technology gained world-wide on both bus and rail, Transport Door Solutions have created doors for the P.S.V. market that are tough, reliable, maintainable, easy to install and safe. The doors utilise specially designed aluminium extrusions, which make them more resistant to damage and vandalism. The basic overall design allows easy installation and adjustment which means lower installation and maintenance costs.

Control systems include: Pneumatic, Electro-Pneumatic or Electric.

SERVICE GUIDELINES

Checks to be carried out upon initial service

SAFETY NOTE: Before any checks are undertaken, Position door in fully closed position. Turn power supply off for the door system via the circuit breaker switch.

These doors are designed for ease of use and operation. The amount of moving parts has been kept to an absolute minimum, thus reducing the levels maintenance required. The following guidelines are our recommended minimum level of service / inspection.

- Manually open and close the door via slide clutch,
- (i) Checking that door is free running.
- (ii) Ensure top seal, aperture seal or door bottom active flaps are not impeding movement.
- (iii) Checking slide clutch is engaging with door in fully closed position against aperture seals, adjust spring tension to suit operation if required (see details for standard setting).
- Check doorguide roller for free movement and integral track on underside of shelf-plate are dry and free from grease.
- Check security of all fasteners and bolts on door-leaves and shelf-plate.
- Check security of all electrical wiring and connections and cables where applicable.
- Visually check all aperture seals / door nosing rubbers, doors, handrails, door-shafts etc for security and damage.

WITH POWER SUPPLY ON

- Operate the doors to check alignment and satisfactory operation. Adjust if necessary.
- Operate the doors to check satisfactory operation of all open and close buttons located in the drivers console, above the doors, and those positioned externally.
- Check reed switch positions, with door(s) closed and open position Adjust if necessary, With slide clutch fully engaged.
- Check all electrical cables are free movement between shelfplate retaining clips to drive unit.

It is important that any components found to be damaged or defective are replaced as soon as possible. Failure to do could result in further damage to other components.

TESTING PROCEDURE

All tests should be undertaken with the door system correctly installed. The engine should be running to provide full electrical power

Conduct the following test and use the fault-finding charts where applicable if a fault is detected. Please note that all tests must be conducted on a stationary vehicle.

- Open and close the doors using the drivers controls (push buttons on console, footswitch on floor etc)
- Remove handbrake and try to open doors from the drivers controls. If a handbrake interlock is fitted, the doors should not open. Re-apply the handbrake when the check is completed.
- Open door using drivers control, remove handbrake, door will automatically close, if fitted
Re-apply the handbrake when the check is completed.
- Open the door by pressing the emergency open button mounted near the door.
- Close the door by pressing the interior close button.
- If obstacle detection is fitted, close the door using the drivers control and obstruct on of the leading edge rubbers. Confirm the doors re-open automatically. Repeat the test, obstructing the other leading edge rubber.
- Manually check slide catch. With door in fully closed position, pull door open using internal pull hand or pushing door from out side. Re-engage clutch by closing door manually or by pressing open button

FAULT FINDING

All tests should be undertaken with the door system correctly installed.

The engine should be running to provide full electrical power.

Conduct the following test and use the fault-finding where applicable if a fault is detected.

Please note that all tests must be conducted on a stationary vehicle.

- A. If one control button is not working:-
Check continuity of switch & cables
- B. If all control buttons are not working:-
Check all buttons are receiving single from multi-plex system. & check "A" as above
- C. If all control buttons are working but door will not operate.
Check to see if motor is running by sound or vibration (touch)
- D. If **YES**:-But ram not extending or retracting, then internal gears are faulty, request replacement drive unit.
- E. If **NO** :- Then motor can be checked. Disconnect plug "5" Short cable from motor red & black connect these to separate power supply. Connect "POSITIVE" to RED . then with "Neg, TOUCH on black if door move in wrong direction reverse connections
DO NOT PERMANENTLY MAKE CONNECTION AS THIS WILL FORCE RAM TO BOTTOM OUT AND JAM UP
- F. If **YES FROM "E" MOTOR IS RUNNING** :- Then NO single from multi-plex system to motor is present.
Check position of reed switches. For factory reset position, Reed switches to line up with marks on drive unit
- G. If door still not operating:- Then Service Agent is required
- H. Please note all above can only be checked if power supply is present to multi-plex & door system also Door cut out switch is in on position
- I. Check for any fuses blown relating to door or multi-plex systems

MAINTENANCE GUIDELINES

1. DAILY SCHEDULE

- Operate the doors to check satisfactory operation of all open and close buttons located in the drivers console, above the doors and those positioned externally.
- Operate the doors to check alignment and satisfactory operation. Adjust if necessary.
- Test the sensitive edge system (if fitted).
- Check the tension for slide clutch

2. MONTHLY SCHEDULE

- Visually check all aperture seals / door nosing rubbers, doors, handrails, door-shafts etc for security and damage. Note that the nosing rubbers contain the sensitive edge components where fitted.
- After releasing all air from the door system, manually open and close the doors, checking that they are free running. Ensure top seal, aperture seal or door active flaps are not impeding movement.
- Check the pneumatic pipes running from the sensitive edge nosing rubber is free from damage, defects and is securely attached to the pressure switch. Check that the pipe is not twisted, distorted, crushed or trapped along its entire length.
-

3. 3 MONTHLY SCHEDULE

In addition to the guidelines stated in the Monthly Schedule:

- Check the general alignment of the door-leaves and check that all fasteners are tight.
- Operate the doors and check that they locate correctly when they are both open and closed. Adjust if necessary.
- Check that shelf-plate fasteners and fixings are tight.
- Check that reed-switches are secure and all fixings are tight.
- Check the condition of electrical wires and connections where applicable. Replace or refit as appropriate.
- Check the condition of pneumatic pipes and fittings where applicable.
- Check the electrical plugs for loose cable connections
- Check the operation of all open / close buttons.
- Check the aperture seals and active flaps for damage or deterioration. Replace as appropriate.
- Clean (with warm soapy water) the door and shelf-plate components, inspecting at the same time for damage or loosening of components.
- *
- *
- *

TYPICAL TOOL REQUIREMENTS



SPANNERS	ALLEN KEYS
Open & Closed Ended	Hex & Ball Nose Ends
24, 23, 22, 19, 17, 16, 13,12, 10, 8, 7, 4, mm A/F	1.5, 2.0, 2.5, 3.0, 4.0, 5.0, 6.0, 8.0, 12. mm A/F
Adjustable Spanner	Tee Bar Type
Up To 25mm Opening S-M-L	3.0, 4.0, 5.0, 6.0, 8.0.
Sockets	



“SCREW DRIVERS BITS”	MISCELLANEOUS
4mm Flat Blade Screwdrivers (S-M-L)	Internal & External Circlip Pliers
No.PZ2 Pozzi-Drive Screwdriver	Pliers flat & tapered ends
No.PZ2 Pozzi-Drive Bit	Stanley Knife
No.PZ3 Pozzi-Drive Bit	Scissors
	Hammer small Combination type



NUT TIGHTENING TORQUE	
M6	7 Nm
M8	17 Nm
M10	36 Nm
M12	55 Nm
M14	80 Nm
M16	120 Nm

BOLT / SCREW TIGHTENING TORQUE	
M6	12 Nm
M8	25 Nm
M10	52 Nm
M12	94 Nm
M16	90 Nm
M20	150 Nm

SHELFPLATE ASSEMBLY

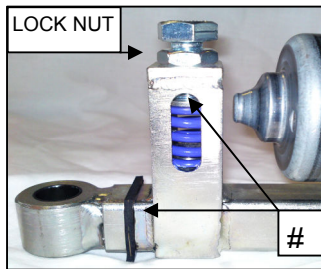
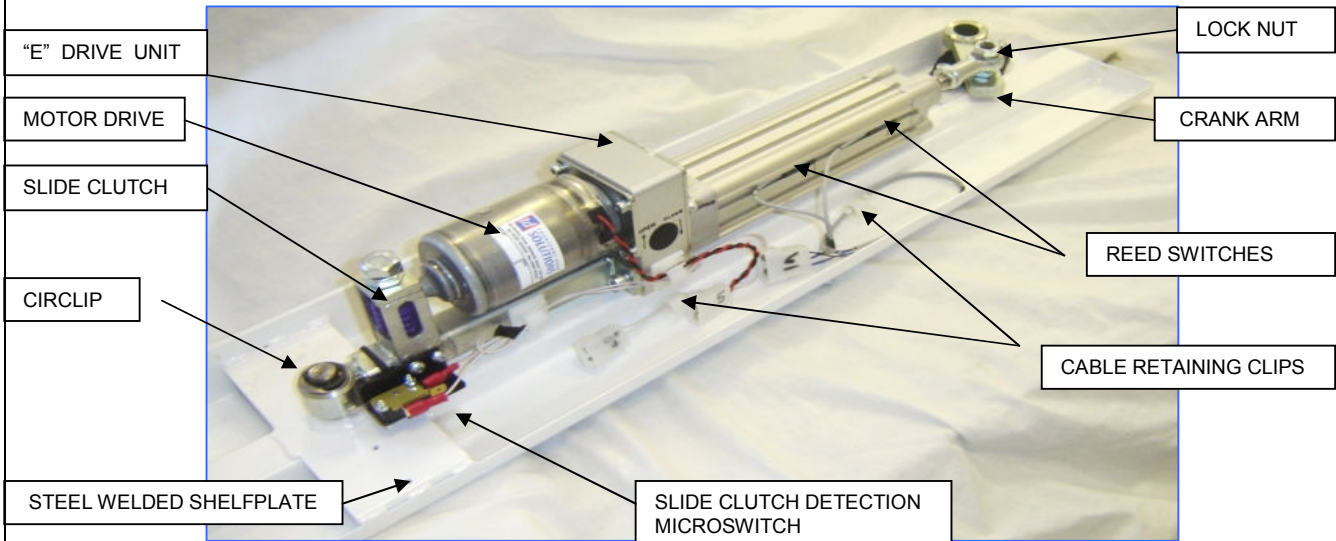

SLIDE CLUTCH. Pre set at factory. Release locking nut, compress or release to suit operation, over-ride Or door retaining force (150N) NOTE POSITION OF SLIDE CLUTCH #

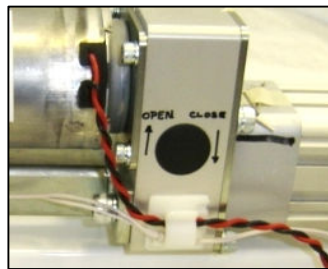

Manual operation of drive unit see instruction label

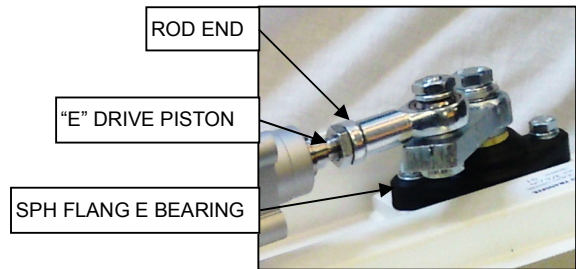

ROD END. To adjust lift off SPH ROD END from crank arm spindle with door in open position. **DO NOT ROTATE "E" DRIVE PISTON**

Part No/Code	Description	
CYL050-12-02	12V "E" DRIVE 100STR UNIT ASSY =CLUTCH, R/SWS, M/SW	
CYL050-24-02	24V "E" DRIVE 100STR UNIT ASSY = CLUTCH, R/SWS, M/SW	
CYL050-12-00	12V "E" DRIVE 100STR UNIT SUB-ASSY = R/SWS	
CYL050-24-00	24V "E" DRIVE 100STR UNIT SUB-ASSY = R/SWS,	
ELE031T-01	12V MOTOR DRIVE PRE-ASSY	INST-014-08
ELE025T-01	24V MOTOR DRIVE PRE-ASSY	INST-014-09
ASY201T	100 SLIDE CLUTCH STD (PURPLE)	INST-014-06
ASY	100 SLIDE CLUTCH STD (BLACK)	

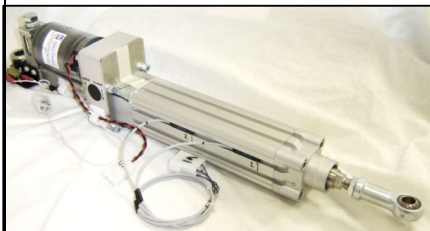

02="E"DRIVE UNIT COMPI FTF



00="E"DRIVE UNIT PRE-ASSY



MOTOR DRIVE ASSY



100 SLIDE CLUTCH ASSY

12v MOTOR PRE-ASSY & CABLE LOOM

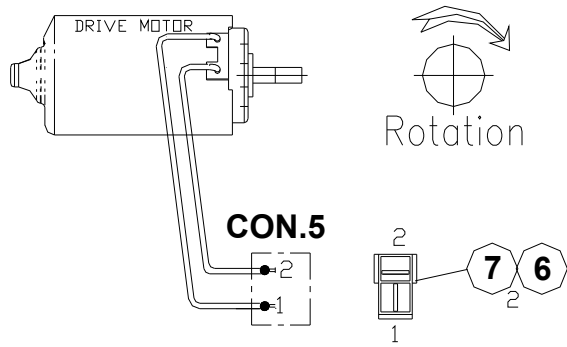
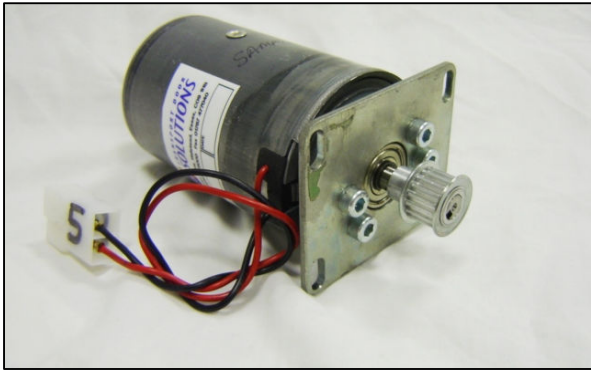

PLUGS-VIEWED ON CABLE ENTRY-

SLIDE CLUTCH DETECTION SWITCH KIT LOOM=EWL212-01

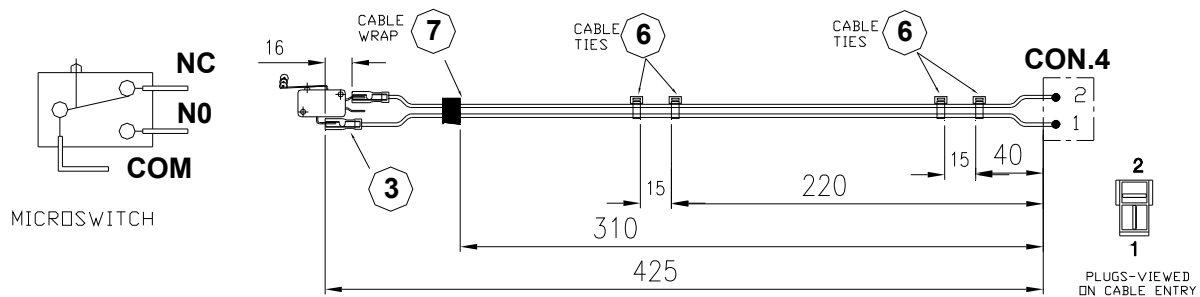

REED SWITCH (NC.) LOOM=EWL212-03 EXAMPLE

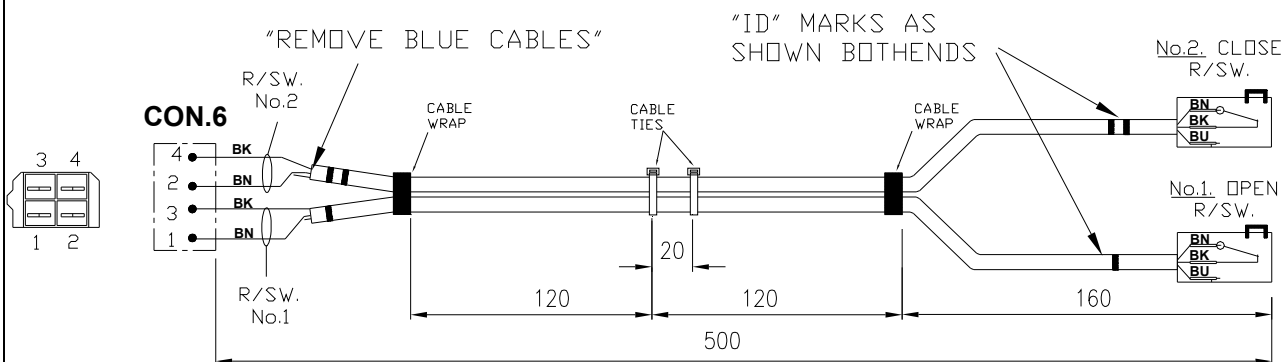

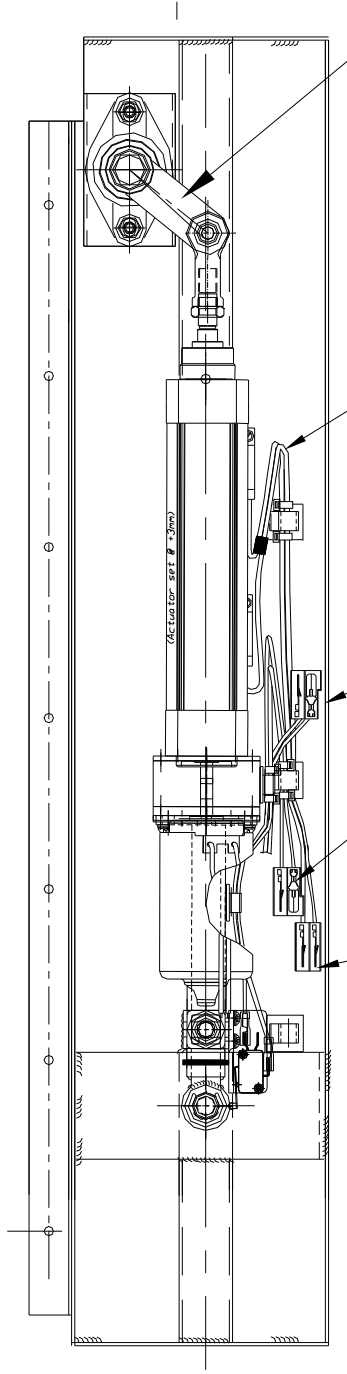

**Crank Arm
R=66**

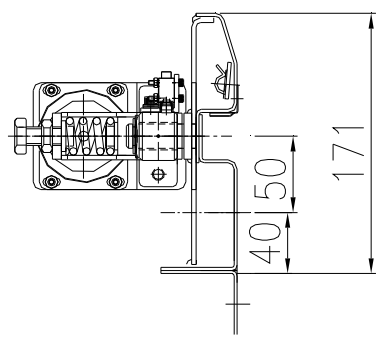
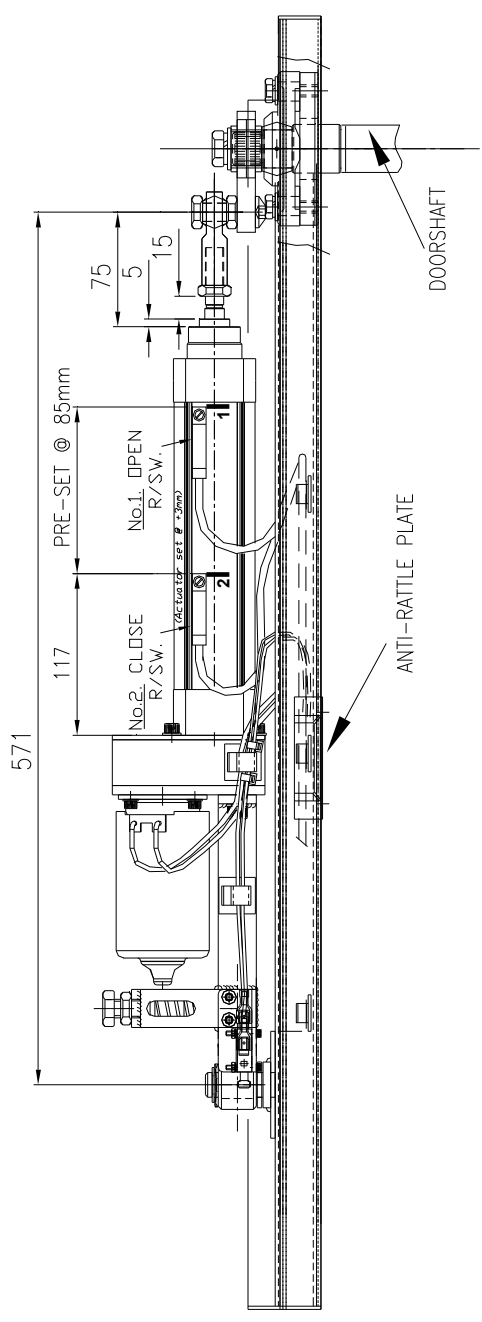

TDS Service Engineer Request Sheet

Report Number : SER/ Allocated by TDS

Operator: _____

Location: _____

Vehicle Type: _____

Reg No: _____

Warranty/ Chargeable? _____
OFFICE USE ONLY

Nature Of Problem:

Cause: Completed by TDS

Corrective Action Taken: Completed by TDS

Parts Used: Completed by TDS

Site time:-		HRS
Travel time:-		HRS
Total time:-		HRS

Customer Sign Off: _____ Date: _____

Printed Name: _____

NOTE IF PARTS FOUND NOT TO BE DEFECTIVE AFTER INVESTIGATION, WE RESERVE THE RIGHT TO RECOVER MATERIAL AND LABOUR COSTS.

Service Engineer: _____ Service Agent: _____



SHEET FOR NOTES/COMMENTS >

(INTENTIONALLY BLANK)